

## **GRINNELL G-FIRE Figure 579 Grooved Rigid Coupling 2 to 8 Inch (DN50 to DN200)**

### **General Description**

The GRINNELL G-FIRE Figure 579 Grooved Rigid Couplings provide a rigid joint by firmly gripping along the full circumference of the pipe grooves. Figure 579 couplings are a dependable method of joining pipe and are an economical alternative to welding, threading, or using flanges.

Figure 579 couplings are rated at pressures up to 365 psi (25,2 bar) depending on pipe size and wall thickness when used in fire protection service applications. Refer to Table A.

#### **NOTICE**

*The GRINNELL G-FIRE Figure 579 Grooved Rigid Coupling described herein must be installed and maintained in compliance with this document, as well as with the applicable standards of the Approval agency, in addition to the standards of any other authorities having jurisdiction. Failure to do so may result in serious personal injury or impair the performance of these devices.*

*Never remove any piping component nor correct or modify any piping deficiencies without first de-pressurizing and draining the system. Failure to do so may result in serious personal injury, property damage, and/or impaired device performance.*

*It is the designer's responsibility to select products suitable for the intended service and to ensure that pressure ratings and performance data are not exceeded. Material and gasket selection should be verified to be compatible for the specific application. Always read and understand the installation instructions.*

*The owner is responsible for maintaining their mechanical system and devices in proper operating condition. Contact the installing contractor or device manufacturer with any questions.*

### **Technical Data**

**Approvals**  
UL and ULC Listed  
FM Approved

Refer to Table A for details.

**Sizes**  
2 to 8 Inch (DN50 to DN200)

**Housing**  
Ductile iron conforming to ASTM A536, Grade 65-45-12

**Finish**

- Orange non-lead paint
- Hot-dipped, Galvanized conforming to ASTM A153

**Bolt/Nut**

- ANSI:  
Carbon Steel oval neck track head bolts are heat-treated and conform to the physical properties of ASTM A183 Grade 2 and SAE J429 Grade 5 with a minimum tensile strength of 110,000 psi.

Carbon Steel heavy hex nuts conform to the physical properties of ASTM A183 Grade 2 and SAE J995 Grade 5. Bolts and nuts are zinc-electroplated conforming to ASTM B633.

**Gaskets**

- Pre-lubricated Grade "A" EPDM, Violet color code, -30°F to 150°F (-34°C to 66°C)

*For dry and freezer systems, lubrication is required. Refer to Installation Manual IH-1000FP for details.*

For proper gasket selection, refer to Technical Data Sheet TFP1895.

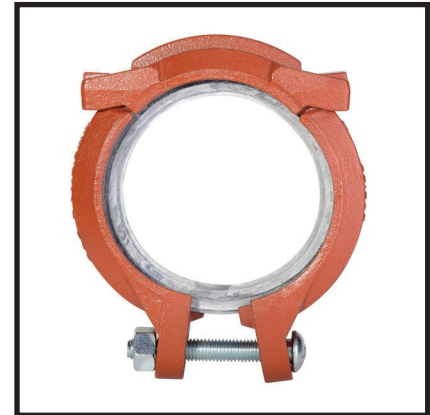

 **ARGCO**  
QUALITY SINCE 1981

For Pricing & Availability,  
call Frank Bishop  
760-305-4017  
[frankb@argco.com](mailto:frankb@argco.com)

Pipe Size		Max. <sup>b</sup> Pressures psi (bar)	Max. <sup>b</sup> End Load Lbs. (kN)	Max. <sup>a, c</sup> End Gap Inches (mm)	Nominal Dimensions						Coupling Bolts		Approx. Weight Lbs. (kg)
Nominal ANSI Inches DN	O.D. Inches (mm)				A (Open) Inches (mm)	A (Closed) Inches (mm)	B (Radius) Inches (mm)	C (Radius) Inches (mm)	D (Radius) Inches (mm)	E Inches (mm)	Qty.	Size Inches	
2 50	2.375 (60,3)	365 (25,2)	1617 (7,19)	0.32 (8,1)	3.92 (99,6)	3.41 (86,5)	2.74 (69,5)	3.69 (93,7)	1.97 (49,9)	2.05 (51,9)	1	3/8 x 2-3/4	1.9 (0,9)
2-1/2 65	2.875 (73,0)	365 (25,2)	2370 (10,54)	0.32 (8,1)	4.48 (113,8)	3.97 (100,7)	2.98 (75,8)	3.89 (98,7)	2.16 (54,9)	2.05 (51,9)	1	3/8 x 2-3/4	2.1 (1,0)
3 80	3.500 (88,9)	365 (25,2)	3512 (15,62)	0.32 (8,1)	5.10 (129,5)	4.57 (116,0)	3.33 (84,5)	4.17 (105,9)	2.59 (65,9)	2.05 (51,9)	1	3/8 x 2-3/4	2.8 (1,3)
4 100	4.500 (114,3)	365 (25,2)	5805 (25,82)	0.32 (8,1)	6.20 (157,5)	5.67 (143,9)	4.14 (105,1)	5.20 (132,2)	3.00 (76,2)	2.05 (51,9)	1	1/2 x 3-1/2	4.0 (1,8)
6 150	6.625 (168,3)	365 (25,2)	12582 (55,97)	0.32 (8,1)	8.85 (224,8)	8.26 (209,8)	5.35 (135,9)	6.26 (159,0)	4.03 (102,3)	2.05 (51,9)	1	1/2 x 3-1/2	6.7 (3,0)
8 200	8.625 (219,1)	365 (25,2)	21326 (94,86)	0.34 (8,6)	11.62 (295,1)	10.77 (273,5)	6.82 (173,1)	7.91 (201,0)	5.33 (135,5)	2.59 (65,8)	1	5/8 x 4-1/8	14.2 (6,4)

**Note:**

- a. Maximum available gap between pipe ends. Minimum gap = 0.120
- b. Maximum Pressure and End Load are total from all loads based on standard weight steel pipe. Pressure ratings and end loads may differ for other pipe materials and/or wall thickness. Contact your TYCO Representative.
- c. Max End Gap is for cut grooved standard weight pipe.

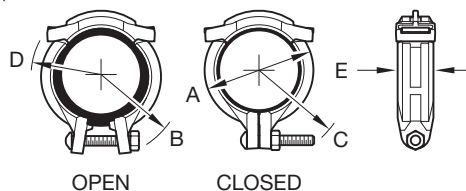

**FIGURE 1**  
**G-FIRE FIGURE 579 GROOVED RIGID COUPLING, 2 TO 8 INCH (DN50 TO DN200)**  
**NOMINAL DIMENSIONS**

Pipe Sizes <sup>c</sup> Nominal ANSI Inches (O.D. mm)	Pipe Schedule <sup>b</sup>	Pressure Rating psi (bar)		
		UL	ULC	FM
2 (60,3)	10	365 (25,2)	365 (25,2)	365 (25,2)
	40	365 (25,2)	365 (25,2)	365 (25,2)
2-1/2 (73,0); 3 (88,9); 4 (114,3)	10	350 (24,1)	350 (24,1)	365 (25,2)
	40	365 (25,2)	365 (25,2)	365 (25,2)
6 (168,3); 8 (219,1) <sup>a</sup>	10	300 (20,7)	300 (20,7)	300 (20,7)
	40	365 (25,2)	365 (25,2)	365 (25,2)

**Note:**

- a. For 8 inch size, minimum allowed pipe wall thickness is 0.188 inches
- b. See Agency website for Listing/Approvals of specialty pipe:  
 UL website - see Online Certificate Directory, [www.ul.com](http://www.ul.com)  
 FM Global website - [www.approvalguide.com](http://www.approvalguide.com)
- c. All couplings approved for dry pipe systems

**TABLE A**  
**LISTED/APPROVED PRESSURE RATINGS**

# Installation

GRINNELL G-FIRE Figure 579 Grooved Rigid Coupling must be installed in accordance with this section.

### General Instructions

Always read and understand the instructions. Never remove any piping component without verifying that the system is depressurized and drained.

The Figure 579 Grooved Rigid Coupling with additional lubrication is recommended for applications below 40°F (4°C).

The installation is based on pipe grooved in accordance with Standard Cut Groove or Roll Groove Specifications. Refer to Technical Data Sheet TFP1898 for additional information.



Step 1.

**Step 1.** Inspect exterior groove and ends of the pipe to verify all burrs, loose debris, dirt, chips, paint and any other foreign material such as grease are removed. Pipe end sealing surfaces must be free from sharp edges, projections, indentations, and/or other defects.

Grade "A" gaskets are supplied with a pre-lubricant and do not require additional lubrication for applications above 40°F (4°C).

**NOTE:** Additional lubrication must be used in dry pipe and freezer applications. A silicone based lubricant is recommended.

To prevent deterioration of the gasket material a petroleum lubricant should not be used on Grade "A" "EPDM".

### NOTICE

Do not remove the hardware from the Figure 579 Grooved Rigid Coupling. Removing the hardware will make it more difficult when installing the coupling to the grooved pipes.



Step 2.

**Step 2.** Do not remove the nut from the bolt. Open the coupling by extending the coupling segments out to the extent allowed by the bolt and nut.



Step 3.

**Step 3.** Push the gasket/coupling onto one end of the pipe until the center-stop of the gasket is in contact with the end of the pipe.

**NOTE:** The gasket center-stop should not ride up onto the gasket sealing surface.



Step 4.

**Step 4.** Slide the other pipe end into the gasket/coupling ensuring that it makes contact with the center stop of the gasket. Both pipes should be aligned vertically and horizontally. Verify that the housing is over the gasket and that the housing keys are aligned with the pipe grooves.



Step 5.

**Step 5.** Tighten nut to the recommended bolt torque (Ref. Table B). Visually inspect the coupling to ensure that the housing keys are engaged into the pipe grooves.

### NOTICE

The 2 to 8 inch couplings have an intended gap of up to 1/16 inch at the bolt pad to allow for positive rigid gripping onto the pipe.

Bolt-torque information is supplied as a guideline and may be used when setting the torque on power impact wrenches. Refer to the manufacturer's instructions for settings.

Bolt Size ANSI Inches	Bolt Torque Range ft-lb
3/8	30-40
1/2	90-110
5/8	130-160

**TABLE B  
BOLT TORQUE  
RECOMMENDATIONS**

Nominal Pipe Size ANSI Inches DN	Pipe O.D. Inches (mm)			A ±0.030 ±0.76mm Inches (mm)	B ±0.030 ±0.76mm Inches (mm)	C Groove Diameter Inches/mm		D Nominal Groove Depth Inches (mm)	T Minimum Wall Inches (mm)	Maximum Allow Flare Diameter Inches (mm)
	O.D. Inches (mm)	Tolerance				Actual	Tol. +0.000			
		+	-							
<b>2</b> DN50	2.375 (60,3)	0.024 (0,61)	0.024 (0,61)	0.625 (15,88)	0.344 (8,74)	2.250 (57,15)	-0.015 (-0,38)	0.062 (1,60)	0.065 (1,65)	2.48 (62,99)
<b>2-1/2</b> DN65	2.875 (73,0)	0.029 (0,74)	0.029 (0,74)	0.625 (15,88)	0.344 (8,74)	2.720 (69,09)	-0.018 (-0,46)	0.078 (1,98)	0.083 (2,11)	2.98 (75,69)
<b>3</b> DN80	3.500 (88,9)	0.035 (0,89)	0.031 (0,79)	0.625 (15,88)	0.344 (8,74)	3.344 (84,94)	-0.018 (-0,46)	0.078 (1,98)	0.083 (2,11)	3.60 (91,44)
<b>4</b> DN100	4.500 (114,3)	0.045 (1,14)	0.031 (0,79)	0.625 (15,88)	0.344 (8,74)	4.334 (110,08)	-0.020 (-0,51)	0.083 (2,11)	0.083 (2,11)	4.60 (116,84)
<b>6</b> DN150	6.625 (168,3)	0.063 (1,60)	0.031 (0,79)	0.625 (15,88)	0.344 (8,74)	6.455 (163,96)	-0.022 (-0,56)	0.085 (2,16)	0.109 (2,77)	6.73 (170,94)
<b>8</b> DN200	8.625 (219,1)	0.063 (1,60)	0.031 (0,79)	0.750 (19,05)	0.469 (11,91)	8.441 (214,40)	-0.025 (-0,64)	0.092 (2,34)	0.109 (2,77)	8.80 (223,52)

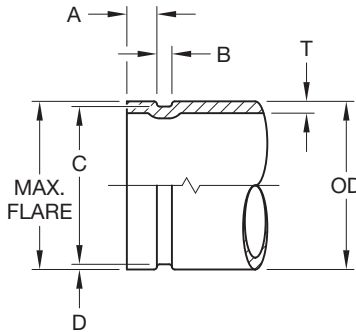

\*Swage grooves must be factory produced by Wheatland Tube Co. and meet standard roll groove dimensions.

**FIGURE 2**  
**STANDARD SPECIFICATION**  
**ROLL GROOVE AND SWAGE GROOVE\***  
**STEEL PIPE**

Nominal Pipe Size ANSI Inches DN	Pipe O.D. Inches (mm)			A ±0.030 ±0.76mm Inches (mm)	B ±0.030 ±0.76mm Inches (mm)	C Groove Diameter Inches/mm		D Nominal Groove Depth Inches (mm)	T Minimum Wall Inches (mm)
	O.D. Inches (mm)	Tolerance				Actual	Tol. +0.000		
		+	-						
<b>2</b> DN50	2.375 (60,3)	0.024 (0,61)	0.024 (0,61)	0.625 (15,88)	0.313 (7,95)	2.250 (57,15)	-0.015 (-0,38)	0.062 (1,60)	0.154 (3,91)
<b>2-1/2</b> DN65	2.875 (73,0)	0.029 (0,74)	0.029 (0,74)	0.625 (15,88)	0.313 (7,95)	2.720 (69,09)	-0.018 (-0,46)	0.078 (1,98)	0.188 (4,78)
<b>3</b> DN80	3.500 (88,9)	0.035 (0,89)	0.031 (0,79)	0.625 (15,88)	0.313 (7,95)	3.344 (84,94)	-0.018 (-0,46)	0.078 (1,98)	0.188 (4,78)
<b>4</b> DN100	4.500 (114,3)	0.045 (1,14)	0.031 (0,79)	0.625 (15,88)	0.375 (9,53)	4.334 (110,08)	-0.020 (-0,51)	0.083 (2,11)	0.203 (5,16)
<b>6</b> DN150	6.625 (168,3)	0.063 (1,60)	0.031 (0,79)	0.625 (15,88)	0.375 (9,53)	6.455 (163,96)	-0.022 (-0,56)	0.085 (2,16)	0.219 (5,56)
<b>8</b> DN200	8.625 (219,1)	0.063 (1,60)	0.031 (0,79)	0.750 (19,05)	0.438 (11,13)	8.441 (214,40)	-0.025 (-0,64)	0.092 (2,34)	0.238 (6,05)

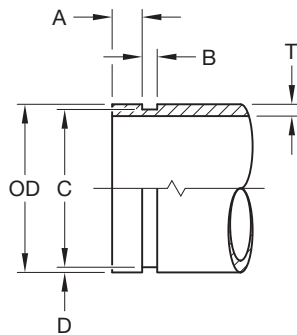

**FIGURE 3**  
**STANDARD SPECIFICATION**  
**CUT GROOVE STEEL PIPE**

## **Care and Maintenance**

The GRINNELL G-FIRE Figure 579 Grooved Rigid Coupling must be maintained in accordance with this section.

Before closing a fire protection system main control valve for maintenance work on the fire protection system that it controls, obtain permission to shut down the affected fire protection system from the proper authorities and notify all personnel who may be affected by this decision.

After placing a fire protection system in service, notify the proper authorities and advise those responsible for monitoring proprietary and/or central station alarms.

The owner is responsible for the inspection, testing, and maintenance of their fire protection system and devices in compliance with this document, as well as with the applicable standards of the National Fire Protection Association (e.g., NFPA 25), in addition to the standards of any authority having jurisdiction. Contact the installing contractor or product manufacturer with any questions. Any impairments must be immediately corrected.

Automatic sprinkler systems are recommended to be inspected, tested, and maintained by a qualified Inspection Service in accordance with local requirements and/or national codes.

## **Limited Warranty**

For warranty terms and conditions, visit [www.tyco-fire.com](http://www.tyco-fire.com).

## **Ordering Procedure**

GRINNELL Products are available globally through a network of distribution centers. For the nearest distributor, visit [www.tyco-fire.com](http://www.tyco-fire.com). When placing an order, indicate the full product name.

Specify: G-FIRE Figure 579 Grooved Rigid Coupling, quantity, pipe size (Nominal ANSI or O.D.), finish (Orange or Galvanized), and Pre-lubricated Grade "A" EPDM gasket.