

FIRE OUTLET TEE THREADED

Model 502



The Model 502 Fire outlet provides a direct branch connection at any location where a hole can be cut in the pipe.

- Available as female threaded outlet
 - Sizes from 1¼ – 2½” | 25 – 76.1 mm
 - Pressures up to 300 psi | 2068 kPa | 21 bar
- Provides a convenient method of incorporating outlets for directly connecting sprinklers, drop nipples, sprigs, gauges, drains and other outlet products.

No need for welding, just cut or drill a hole at the desired outlet location.

The Fire outlet allows full bore flow and is pressure rated to 300 psi (20 bar).

Pipe Material

- Carbon steel, Schedule 10, Schedule 40.

Maximum Working Pressure

- Up to 300 psi/20 bar

Function

- Joins carbon steel pipe.
- Provides a rigid pipe joint designed to restrict axial or angular movement.

CERTIFICATIONS/LISTINGS

Underwriters Laboratories, Underwriters Laboratories Canada, Factory Mutual.

SPECIFICATIONS - MATERIAL

Housing Sections: Ductile Iron conforming to ASTM A 536, Grade 65-45-12.

Housing Coating:

Standard: Orange Enamel

Available: Hot Dipped Galvanized

Gasket:

Standard: Grade E EPDM (Type A)

ARGCO's products are listed by Underwriters Laboratories UL Canada and Approved by Factory Mutual for wet and dry (oil free air) sprinkler services within the rated working pressure.

Bolts and Nuts

Standard: Carbon Steel oval neck track bolts meeting ASTM A449 and ISO 898-1. Carbon steel hex nuts meet ASTM A563 Grade B.

Nuts and Bolts are zinc electroplated per ASTM B633 NZ/FE5, finish Type III.

Available: Stainless Steel. Meets ASTM F593, Group 2 (316 stainless steel), condition CW.

Hex nuts meets ASTM F594, Group 2 (316 stainless steel), condition CW, with galling-resistant coating.

System No.		Location		Spec Section		Paragraph	
Submitted By		Date		Approved		Date	

FIRE OUTLET TEE THREADED]

Model 502

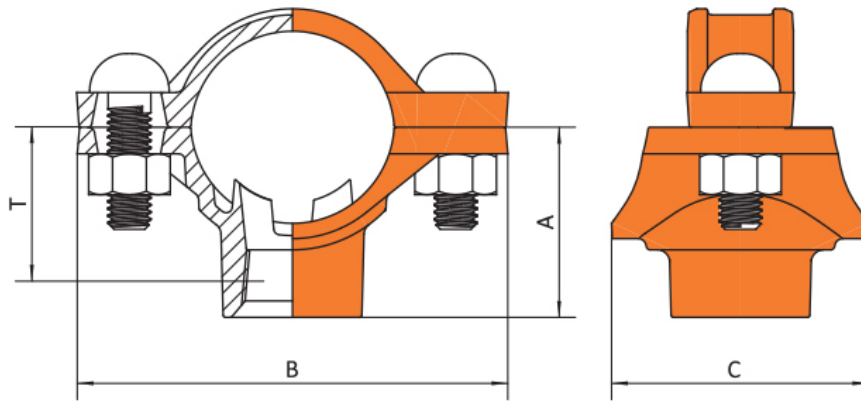

Item #	Nominal Size in/mm	Hole Dia. T +0.04, -0 +1, -0	Hole Saw Size in/mm	Dimensions			Take-Out T/D in/mm	Bolt Size in	Bolt Torque N-M/Lbs-Ft
				A inches mm	B inches mm	C inches mm			
7010300	1 x 1-1/2	0.95	15/16	1.10	3.66	1.89	1.14	3/8	22-29
100050	25 x 40	24	24	28	93	48	29		30-40
7010300	1-1/4 x 1/2	1.18	1-3/16	1.77	3.86	2.56	1.30	3/8	22-29
125050	35 x 15	30	30	45	98	65	33		30-40
7010300	1-1/4 x 3/4	1.18	1-3/16	1.77	3.86	2.56	1.28	3/8	22-29
125075	32 x 20	30	30	45	98	65	32.5		30-40
7010300	1-1/4 x 1	1.18	1-3/16	2.13	3.86	2.20	1.52	3/8	22-29
125100	32 x 25	30	30	54	98	56	38.6		30-40
7010300	1-1/2 x 1/2	1.18	1-3/16	1.89	3.86	2.20	1.42	3/8	22-29
150050	40 x 15	30	30	48	98	56	36.1		30-40
7010300	1-1/2 x 3/4	1.18	1-3/16	1.89	3.86	2.20	1.40	3/8	22-29
150075	40 x 20	30	30	48	98	56	35.6		30-40
7010300	1-1/2 x 1	1.18	1-3/16	2.24	3.86	2.20	1.64	3/8	22-29
150100	40 x 25	30	30	57	98	56	41.7		30-40
7010300	2 x 1/2	1.18	1-3/16	2.13	3.86	2.20	1.66	3/8	22-29
200050	50 x 15	30	30	54	98	56	42.2		30-40
7010300	2 x 3/4	1.18	1-3/16	2.13	3.86	2.20	1.64	3/8	22-29
200075	50 x 20	30	30	54	98	56	41.7		30-40
7010300	2 x 1	1.18	1-3/16	2.44	3.86	2.20	1.88	3/8	22-29
200100	50 x 25	30	30	62	98	56	47.8		30-40
7010300	2-1/2 x 1/2	1.18	1-3/16	2.40	3.86	2.20	1.91	3/8	22-29
250005	65 x 15	30	30	61	98	56	48.5		30-40
7010300	2-1/2 x 3/4	1.18	1-3/16	2.40	3.86	2.20	1.89	3/8	22-29
250075	65 x 20	30	30	61	98	56	48		30-40
7010300	2-1/2 x 1	1.18	1-3/16	2.80	3.86	2.20	2.13	3/8	22-29
250100	65 x 25	30	30	71	98	56	54.1		30-40

System No.		Location		Spec Section		Paragraph	
Submitted By		Date		Approved		Date	