

# USER GUIDE

---



## ARGCO RGEH-840A ELECTRIC HYDRAULIC ROLL GROOVER 1" to 12" CAPACITY



## WARNING:

**Read this Operator's Manual carefully before using this tool. Failure to understand and follow the contents of this manual may result in electrical shock, fire and/or serious personal injury.**

## GENERAL SAFETY REQUIREMENTS

### Work Area Safety

- Keep work zone **clean and well lit**. Cluttered or dark areas may cause accidents.
- **Do not operate groover in explosive atmospheres**, such as in the presence of flammable liquids, gases, or dust. Groover can create sparks which may ignite the dust or fumes.
- **Keep children and other personnel away** while operating a roll groover.
- Keep floors dry and **free of slippery materials** such as oil.

### Personal Safety

- **Stay alert** while operating a groover. Do not use a groover while fatigued or under the influence of drugs, alcohol, or medication. Inattention when using a groover may result in serious personal injury.
- Use **personal protective equipment**. Always wear safety glasses.
- **Remove any adjusting rulers or wrenches before using groover**. Tools left attached to a rotating part of the groover may result in personal injury.
- **Dress properly**. Do not wear loose clothing or jewelry. Keep hair, clothing, and gloves away from moving parts.

### Electrical Safety

- **Power tool plugs must match the outlet. Never modify the plug in any way**. Do not use any adapter plugs with grounded power tools. Unmodified plugs and matching outlets will reduce risk of electric shock.
- **Avoid body contact with grounded surfaces, such as pipes or radiators**. There is an increased risk of electric shock if your body is grounded.
- **Do not expose power tools to rain or wet conditions**. Water entering a power tool can cause electric shock.
- **Do not abuse the cord. Never use the cord for carrying, pulling or unplugging the power tool. Keep cord away from heat, oil, sharp edges or moving parts**. Damage or entangled cords increase the risk of electric shock.
- **When operating a power tool outdoors, use an extension cord suitable for outdoor use**.
- **If operating a power tool in a damp location, use a Ground Fault Circuit Interrupter (GFCI) protected supply**.

## Power Tool Use and Care

- **Always use the correct power tool for each application.** The correct power tool will do the job right and safely.
- **Do not use the power tool if the switch does not turn it ON and OFF.** Any power tool that cannot be controlled with the switch is dangerous and must be repaired.
- **Disconnect the plug from the power source before making any adjustments, changing accessories or storing power tools.**
- **Store idle tools away from children** and do not allow persons unfamiliar with the tool or these instructions to use the groover. Roll groovers are dangerous in the hands of untrained users.
- **Maintain tools.** Check for misalignment or binding of moving parts, breakage of parts and any other condition that may affect the tool's operation. If damaged, have the tool repaired before use.
- Use only accessories that are recommended for ARGCO RGEH-840 Electronic Hydraulic Roll Groover.
- **Keep handles dry and clean;** free from oil and grease.

## Service

- **Have the roll groover serviced only by a qualified repair person using identical replacement parts.**

## Foot Switch Safety

**Using the electric roll groover without a foot switch increases the risk of serious injury. A foot switch provides better control by letting the operating personnel shut off the motor by simply removing their foot. If clothing should become caught in the machine, it can continue to roll and pull personnel into the machine. Because the roll groover has high torque, the clothing itself can bind around arms or other body parts with enough force to crush or break bones.**

## Roll Groover Safety

- **Keep hands away from grooving rolls.** Do not wear loose fitting gloves.
- **Keep hands away from ends of pipe.** Burrs and sharp edges may catch and cut.
- **Properly support the pipe** to prevent the tipping of the pipe and equipment.
- **Set-up the groover on a flat, level surface.** Be sure the machine, stand and groover are stable.
- **Always wear appropriate personal protective equipment** such as safety glasses, tight fitting leather gloves, steel toed footwear, and a hardhat.
- **Do not wear loose clothing. Keep sleeves and jackets buttoned. Do not reach across the machine or pipe.** Clothing can be caught by the pipe resulting in entanglement and serious injury.
- **Do not use this groover without a foot switch.** A foot switch is a safety device used to prevent serious injury.
- **Only use a roll groover to groove pipe of recommended sizes and types according to these instruction.** Improper use or modification of the roll groover for other applications may increase the risk of injury.



## DESCRIPTION, SPECIFICATIONS and STANDARD EQUIPMENT DESCRIPTION

ARGCO RGEH-840A Universal Electric Hydraulic Roll Groover is a motor driven roll groover designed with an advanced hydraulic feeding system. It can form roll grooves in carbon steel and stainless steel pipe of **1" thru 8" diameter SCH10/40 and 10" thru 12" SCH10/20 pipes**. The grooves are formed by mechanically advancing a grooving roller into the pipe which is supported by a knurl drive roller. The only adjustment necessary is for the depth of the groove. Unique integrated drive roller with draft shaft reduces the chance of drive shaft breakage. The ARGCO RGEH-840A Electric Hydraulic Roll Groover is an ideal tool for **light and medium volume work** on job sites and for workshop in-house fabrication on all **1"~12"** pipes.



### Specifications

Capacity .....	1" – 8" Schedule 10/40 CS/SS pipe with roll change 10" – 12" Schedule 10/20 CS/SS pipe with roll change (See Chart A for groove specification)
Max. allowance of pipe thickness.....	8mm / 5/16inch
Max. hydraulic pressure of cylinder.....	35Mpa / 350 bars / 5000psi
Max. extrusion force.....	6,000kgs / 13,200lbs
Capacity of hydraulic oil reservoir.....	110mL / 3¾ fl.oz.
Grooving speed (w/ 1400rpm gear motor) .....	23 r.p.m.
Groove Diameter Lock device.....	Stop knob
Operation Methods.....	Single phase motor 1100W / 110~240V / 50/60Hz , or Three phase motor 750W / 380V / 50/60Hz (optional)
Actuation.....	Hydraulic Hand Pump
Weight .....	approx.95kgs/ 200 lbs.
Packing size L×W×H .....	750mm×400mm×770mm / 29.5"×15.7"×30.3"
Groove specification.....	AWWA C606-87

## GROOVING PROCESS

### Work Area & Machine Set-up

1. Make sure the work area follows these guidelines:
  - Adequate lighting
  - No flammable liquids, vapors or dust that may ignite.
  - Grounded electrical outlet
  - Clear path to the electrical outlet without any oil, sharp edges or moving parts which may damage the electric cord.
  - Dry place for machine and operator. Do not use the machine when standing in water.
  - Level ground
  - Clean the work area prior to setting up any equipment.
2. Use one person to lift the roll groover and second person to inserts the four support legs
3. into the base sockets.

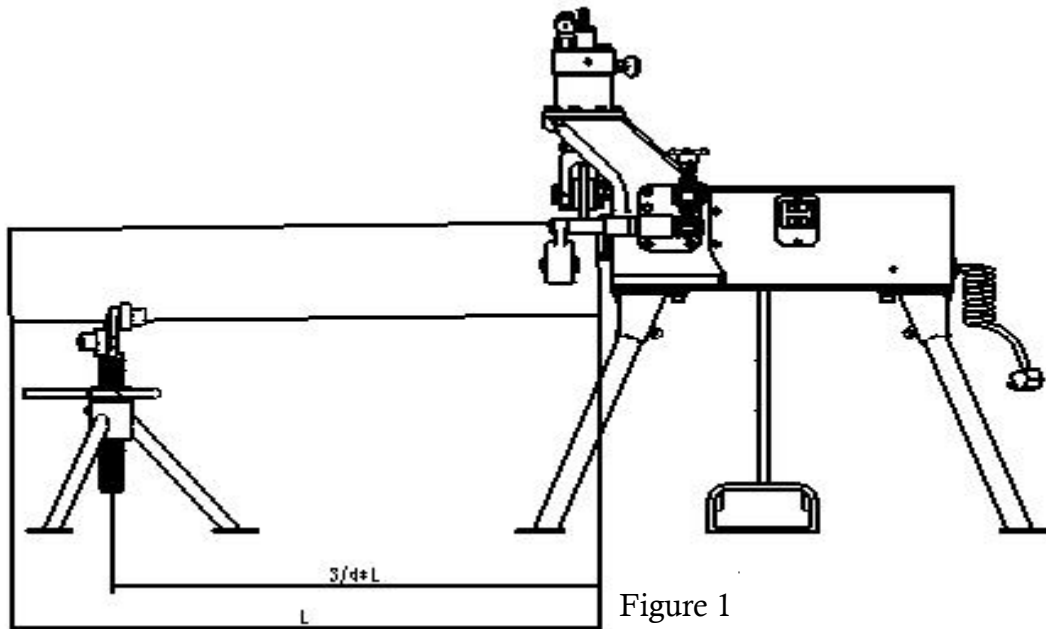

Figure 1

3. Turn the upper portion of the leg until the foot makes full contact with ground. Adjust all four legs until the machine is level. Secure set screws to fix legs.
4. Install pump handle with included pin.
5. Make sure the power switch is in the OFF position.
6. Place the foot switch where the operator can safely control the roll groover and pipe.
7. It should allow the operator to do the following:
  - Stand facing the hydraulic pump.
  - Control the foot switch with left foot.
  - Have convenient access to the groover and hydraulic pump without reaching across the machine.
8. Plug the machine into the power socket and make sure cord is in good condition.

9. Inspect the roll groover using the following steps:

- Turn the power switch to the ON position.
- Press and release the foot switch. Check that the groove roller rotates in a counterclockwise direction as the operator faces the groover.
- Depress the foot switch and hold. Inspect all moving parts for misalignment, binding, odd noise or any other unusual conditions.
- Release foot switch and turn the power switch to the OFF position.

If anything that may affect the safe and normal operation of the machine is found, have the roll groover repaired before use.

## Pipe Preparation

These are generalized instruction only. Always follow grooved coupling manufacturer's specific recommendations for pipe end preparation. Failure to follow the grooved coupling manufacturer's recommendations may lead to an improper connection and cause leaks.

1. Cut pipe to proper length. Make sure pipe end is square and free of burrs. Cut off method and large burrs can affect the quality of the groove made and the tracking of the groove. Do not attempt to groove pipe that has been cut with a torch.
2. All internal/external weld bead, flash, or seams must be ground flush at least 2" from the end of the pipe. Do not cut flats into gasket seat area, this could cause leaks.
3. Remove all scale, dirt, rust and other contaminants **at least 2"/50mm** from the end of the pipe. Contaminants can clog the drive knurls and prevent proper driving and tracking of the pipe while grooving.
4. Make sure that the pipes to be grooved have appropriate support. When using one pipe stand, make sure the stand supports the pipe 3/4 of the total length from the grooved end. **Refer to Figure 1.**
5. Pipes equal to or **over 108"/3.0meter** should be supported with **at least two pipe stands**. Locate each stand at 1/3 of the total length of the pipe. Failure to properly support the pipe may allow the pipe or the pipe and machine to tip and fall.
6. Square the pipe and pipe support to roll groover making sure pipe is flush against drive roll plate.
7. Using a level verify that the pipe is level or sloped slightly downward away from the operator (pipe stand slightly lower than the groove machine about 1°-2°).
8. Turn the power switch to ON position, depress the foot switch and hold. Observe the pipe rotation. If the pipe turns spiral and tends to "walk off" the drive roll, check setup and level status of the pipe. If correct, slightly offset the pipe and pipe stands approximately 1°-2° degree (about 2" over at 10 feet/ 50mm over at 3.0meters from the roll groover) away from the operator. Recheck the rotation until pipe turns stable.



## Start A Test Grooving

A test grooving should be always performed when setting up or changing pipe sizes.

1. Turn the pump release valve clockwise till closed. Press down the pump handle to push down the groove roller in contact with the pipe top surface.
2. Turn the stop nut clockwise until it contacts the oil cylinder surface. The pipe and roll groover should be secure to each other at this stage. Refer to Figure 2.
3. Depending on the required groove depth (refer to Chart A “Groove Parameters”), turn the stop nut counter-clockwise. Each full circle is approximately 1/16” (2mm).
4. Turn the stabilizer knob clockwise until the stabilizer touches the pipe body.
5. Start the roll groover by pressing the foot switch while using the pump handle. Allow one full pipe rotation between half strokes of the pump handle.
6. When the stop nut contacts the cylinder top surface, allow two more full pipe rotation.
7. Stop the roll groover by releasing foot switch. Turn the pump knob counter-clockwise and perform groove inspection. Use groove tape to check groove diameter.
8. If the groove is too large, the groover can be adjusted and the groove will be made smaller by turning stop nut counter-clockwise slightly. Repeat steps 4 -6. If the groove is too small, turn the stop knob clockwise slightly. Another groove will need to be made. Proper groove diameter is important to insure connection performance. Out of specification grooves could cause joint failure.

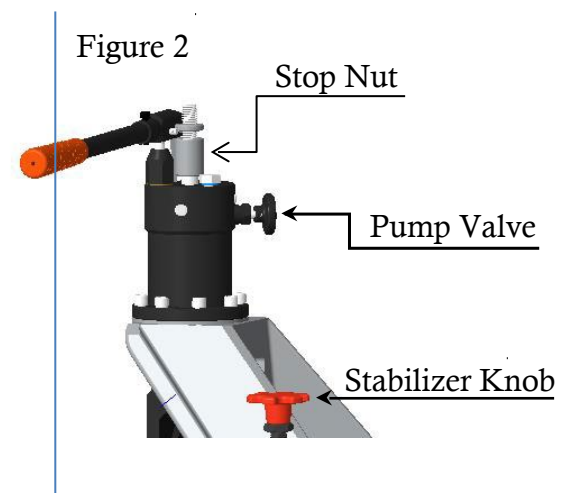

## Roll grooving with RGEH-840A

1. After the test groove is made and the groove meets requirement, tighten the lock nut and fix the stop nut at the proper groove depth. The roll groover is ready to use on pipe the same size.
2. Repeat “Pipe Preparation” section and steps 4-7 in “Start a test groove” for more grooving.
3. **Implement at least one groove diameter inspection after every 5 grooves.**



## Changing Roll Sets

1. Turn the valve on hydraulic pump counter-clockwise and raise the groove roller to the top position. Refer to Figure 3.
  2. Remove Groove Roll  
Loosen the setscrew on the side block with a 3/16" (5mm) hex wrench. Grasp the groove roller steady and remove the groove shaft from the side block. Refer to Figure 4.
  3. Remove Drive Roll  
Loosen the flush bolt in the center of drive shaft with a 5/16"(10mm) hex wrench. Grasp the knurl drive roller and remove the drive shaft.
  4. Reverse step 2 & 3, install suitable groove roller and drive roller shaft as required.
- ★ **All rollers use flat bearing. Do not drop the bearings and covers.**

Figure 3

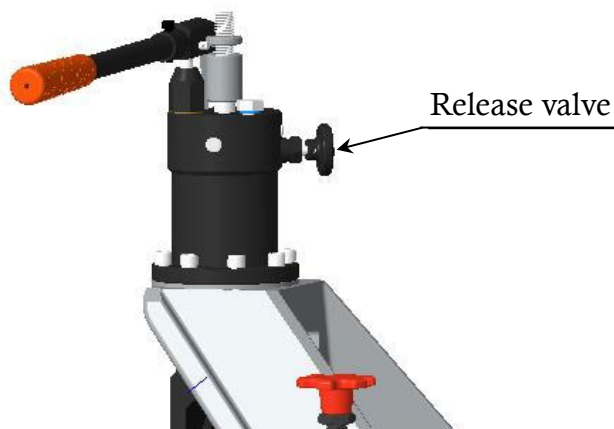
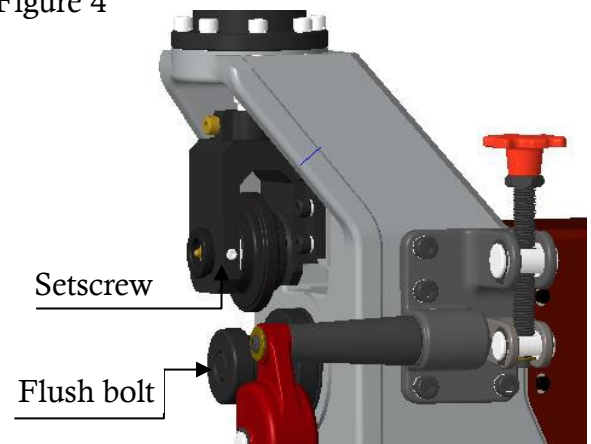

Figure 4



## MAINTENANCE INSTRUCTIONS

### Lubrication

ARGCO RGEH-840A Universal Electric Hydraulic Roll Groover should be lubricated with a good general purpose grease periodically as specified below.

- 2 Grease nozzles are integrated on RGEH-840A groover. The grease nozzle for drive shaft lubrication is located on the side of the groover housing. The grease nozzle for roll shaft is at the front-center of the roll shaft. Always add grease until a small amount is pushed out.
- **At least every 4 hours of operation**, lubricate the roll shaft.
- **Every month**, add grease to the drive shaft lubrication nozzle.
- The gear box of the RGEH-840A Roll Groover is greased for life and does not require the addition of any grease unless the gear box is opened. See Inspection Section for other information on maintenance.
- Grease the bearing prior assembling when repairing the roll groover.

## Cleaning

- Clean the driveshaft knurls with a wire brush on a daily basis or more often if needed.
- Clean the unit surface with dry soft cotton cloth.

## Machine Storage

- Store the tool in a locked area that is out of reach of children and people unfamiliar with roll groover equipment. This tool can cause serious injury in the hands of untrained users.
- Store the tool in a locked area away from moisture and corrosion material. Apply a thin coat of anti-rust liquid on moving parts and shafts is strongly recommended.

## Accessories

The following ARGCO products have been designed to function with the RGEH-840A Universal Electric Hydraulic Roll Groover. Other accessories suitable for use with other tools may be hazardous when used on the RGEH-840A Roll Groover. To reduce the risk of serious injury, only use accessories specifically designed and recommended for use with the RGEH-840A Hydraulic Roll Groover, such as those listed below.

## Standard Equipment & Item Code of

### ARGCO RGEH-840A Universal Electric Hydraulic Roll Groover

- |  |  |
|--|--|
| ■ #99037 RGEH-840 Roll groover                               | ■ #11109 & #12043 Roller set for 8 " ~ 12" |
| ■ #98055 Single phase motor --<br>1100W / 110-240V / 50/60Hz | ■ #98078 Pipe stand for 1" ~ 12"           |
| ■ #98009 Hydraulic pump                                      | ■ #98026 Foot switch                       |
| ■ #11106 & #12041 Roller set for 1" ~ 1½"                    | ■ #98011 Pipe stabilizer                   |
| ■ #11107 & #12042 Roller set for 2" ~ 3"                     |  |
| ■ #11108 & #12042 Roller set for 3½" ~ 6"                    |  |

## Troubleshooting

Problem	Cause	Correction
<b>Pump not delivering oil, cylinder does not advance</b>	Low hydraulic oil in reservoir	Check oil level and add hydraulic oil if necessary.
	Low quality oil, pump nozzle blocked.	Change qualified oil and flush the oil tube.
	Seat inside the check valve worn or leak.	Loose screws and spring, knock the steel shot with proper tool and recreate sealing.
<b>Unusual loud and sharp noise from the pipe when grooving.</b>	Wrong position of pipe stand with long pipe causes echo..	Relocate the pipe stand to right or left.
	Pipe end not square cut with pipe axis. Pipe end scratch the drive shaft plate.	Cut pipe end square.
	Excessive friction between pipe and drive roll.	Apply a thin coat of grease on pipe end.
<b>Pipe will not track while grooving</b>	Pipe not level.	Adjust stand to level pipe.
	Stabilizer wheel not engaging pipe.	Offset pipe 1°-2° and tight the stabilizer again.
	Groover not level.	Level groover.
<b>Pipe rocks from side to side</b>	Improper setup of pipe stand.	Adjust the pipe stand location, direction and height.
	Pipe end flattened or damaged	Cut off damaged pipe end or grind flat.

## Service and Repair

The “Maintenance Instructions” will take care of most of the service needs of this machine. Any problems not addressed by this section should only be handled by an authorized ARGCO service technician. Tools should only be taken to an ARGCO Independent Authorized Service Center or returned to the factory. When servicing this machine, only identical replacement parts should be used. Use of other parts may create a risk of serious injury.

## Chart A -Roll grooving parameters

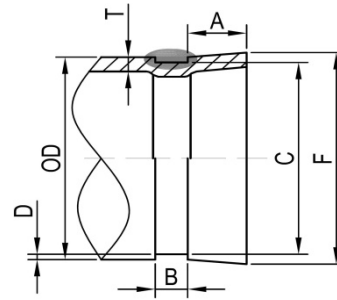
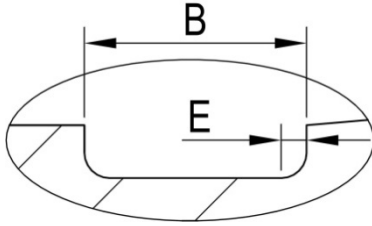

Nom. Pipe Size	Pipe O.D.			Gasket Seat A ±0.03in. ±0.76mm	Groove Width B ±0.03in. ±0.76mm	Groove Diameter		Groove Depth D(ref.) in. mm	Allow. Flare Dia. F(max) in. mm
	Basic in. mm	Tolerance +in. + mm	-in. -mm			Basic in. mm	Tol. in. mm		
1" 25	1.325 33.7	0.013 0.33	0.027 0.68	0.625 15.88	0.281 7.14	1.535 38.99	-0.015 -0.38	0.063 1.60	1.36 34.5
1¼" 32	1.660 42.4	0.016 0.41	0.024 0.60	0.625 15.88	0.281 7.14	1.775 45.09	-0.015 -0.38	0.063 1.60	1.77 45.0
1½" 40	1.900 48.3	0.019 0.48	0.020 0.52	0.625 15.885	0.281 7.14	2.12 53.85	-0.015 -0.38	0.063 1.60	2.01 51.1
2" 50	2.375 60.3	0.024 0.61	0.024 0.61	0.625 15.88	0.344 8.74	2.250 57.15	-0.015 -0.38	0.063 1.60	2.48 63.0
2½" 65	2.875 73.0	0.029 0.74	0.029 0.74	0.625 15.88	0.344 8.74	2.720 69.09	-0.018 -0.46	0.078 1.98	2.98 75.7
3OD 65	3.000 76.1	0.030 0.76	0.030 0.76	0.625 15.88	0.344 8.74	2.845 72.26	-0.018 -0.46	0.078 1.98	3.10 78.7
3" 80	3.500 88.9	0.035 0.89	0.031 0.79	0.625 15.88	0.344 8.74	3.344 84.94	-0.018 -0.46	0.078 1.98	3.60 91.4
3½" 90	4.000 101.6	0.040 1.02	0.031 0.79	0.625 15.88	0.344 8.74	3.834 97.38	-0.020 -0.51	0.083 2.11	4.10 104.1
4" 100	4.500 114.3	0.045 1.14	0.031 0.79	0.625 15.88	0.344 8.74	4.334 110.08	-0.020 -0.51	0.083 2.11	4.60 116.8
4½OD 120	5.000 127.0	0.050 1.27	0.031 0.79	0.625 15.88	0.344 8.74	4.834 122.78	-0.020 -0.51	0.083 2.11	5.10 129.5
5½OD 125	5.500 139.7	0.056 1.42	0.031 0.79	0.625 15.88	0.344 8.74	5.334 135.48	-0.020 -0.51	0.083 2.11	5.60 142.2
5" 125	5.563 141.3	0.056 1.42	0.031 0.79	0.625 15.88	0.344 8.74	5.395 137.03	-0.022 -0.56	0.084 2.13	5.66 143.8
6½OD 150	6.500 165.1	0.063 1.60	0.031 0.79	0.625 15.88	0.344 8.74	6.330 160.78	-0.022 -0.56	0.085 2.16	6.60 167.6
6" 150	6.625 168.3	0.063 1.60	0.031 0.79	0.625 15.88	0.344 8.74	6.455 163.96	-0.022 -0.56	0.085 2.16	6.73 170.9
8OD 200	8.000 203.2	0.063 1.60	0.031 0.79	0.750 19.05	0.469 11.91	7.816 198.53	-0.025 -0.64	0.092 2.34	8.17 207.5
8" 200	8.625 219.1	0.063 1.60	0.031 0.79	0.750 19.05	0.469 11.91	8.441 214.40	-0.025 -0.64	0.092 2.34	8.80 223.5
10OD 250	10.000 254.0	0.063 1.60	0.031 0.79	0.750 19.05	0.469 11.91	9.812 249.23	-0.027 -0.69	0.094 2.39	10.17 258.3
10" 250	10.750 273.0	0.063 1.60	0.031 0.79	0.750 19.05	0.469 11.91	10.562 268.28	-0.027 -0.69	0.094 2.39	10.92 277.4
12OD 300	12.000 304.8	0.063 1.60	0.031 0.79	0.750 19.05	0.469 11.91	11.781 299.24	-0.030 -0.76	0.109 2.77	12.17 309.1
12" 300	12.750 323.9	0.063 1.60	0.031 0.79	0.750 19.05	0.469 11.91	12.531 318.29	-0.030 -0.76	0.109 2.77	12.92 328.2