

1	Safety notes	35
	1.1 Correct use	35
	1.2 Safety symbols used and their meanings	35
	1.3 Notes on safety for persons and the machine	35
2	Technical data	37
	2.1 Technical data SUPERTRONIC 2 SE	37
	2.1 Technical data SUPERTRONIC 3 SE	38
	2.1 Technical data SUPERTRONIC 4 SE	38
3	Functions of the thread-tapping machine	38
	3.1 Overview / accessories / description	38
	3.1.1 Overview, thread-tapping machine	38
	3.1.2 Overview, thread-tapping heads 2 SE and 3 SE	38
	3.1.3 Accessories	39
	3.1.4 Functional description	40
4	Preparations for operation	40
	4.1 Scope of delivery	40
	4.2 Transporting the thread-tapping machine	40
	4.3 Setting up the machine	41
	4.4 Electrical connection of the machine	41
	4.5 The thread-tapping oil	42
	4.6 Checking the thread-tapping oil	43
	4.7 Adjusting the delivered thread-tapping oil quantity	43
	4.8 Draining off the oil	44
5	Operation of the thread-tapping machine	44
	5.1 Clamping the workpieces	44
	5.2 Cutting the workpieces with the pipe cutter (1)	45
	5.3 Reaming the workpieces	46
	5.4 Changing the thread size	47
	5.4.1 Thread-tapping machine SUPERTRONIC 2 SE	47
	5.4.2 Thread-tapping machine SUPERTRONIC 3 SE	47
	5.4.2 Thread-tapping machine SUPERTRONIC 4 SE	47
	5.5 Removing and installing the thread jaws from and in the thread-tapping head (10) in the tool carriages (4)	48
	5.5.1 Automatic thread-tapping head	48
	5.5.2 Standard thread-tapping head	50
	5.6 Changing the complete thread jaws and the thread-tapping head	51
	5.7 Changing the thread size	51
	5.8 Tapping threads	52
	5.9 Setting the thread length (only automatic thread-tapping head)	54
	5.10 Setting the thread depth (only automatic thread-tapping head)	55
	5.10.1 Only thread-tapping machine SUPERTRONIC 2 SE	55
	5.10.2 Only thread-tapping machine SUPERTRONIC 3 SE/4 SE	55

Contents

	<u>Page</u>	
5.11	Thread-tapping in 2 work steps (automatic thread-tapping head 2 ½" ... 3")	56
5.12	Removing the workpiece	56
5.13	Cleaning after use	56
6	Maintenance and inspection	57
6.1	Changing the internal deburring blade	57
6.2	Changing the pipe cutter cutting blade	57
6.3	Changing the clamping jaw insert	58
6.4	Daily inspection	60
7	Troubleshooting	60
8	Disposal	60
8.1	Metal, electrical and electronic parts	60
8.2	Oils and lubricants	61
8.3	Waste from repair work	61
9	Warranty	61
10	Customer service	61

1. Safety notes

1.1 Correct use

The thread-tapping machine SUPERTRONIC 2 SE; 3 SE and 4 SE may only be used for cutting off, making and deburring BSPT, NPT and bolt threads measuring ¼" ... 2" (2 SE), ½" ... 3" (3 SE) and ¼" ... 4" (4 SE) as described in Chapter 2 "Technical data".

The SUPERTRONIC thread-tapping machines may only be operated with suitable standard and automatic tapping heads that have been inspected and recommended by ROTHENBERGER Werkzeuge GmbH, and with thread-tapping jaws as described in Chapter 2 "Technical data".

Correct use of accessories:

Use the accessories available from the main catalogue only as described in the catalogue and as stated in the operating instructions.

The supplied safety pedal carries the GS approval of the professional liability insurers' association and is compulsory for using the machine in the Federal Republic of Germany.

Never make technical or design modifications to the thread-tapping machine and to the accessory parts. This would render the operating permit void and would represent an accident and injury risk.

When using electrical tools and machines, basic safety measures must be observed and followed in order to provide protection against electric shock, injury and fire risks. Read the instructions precisely before using the machine. Always keep the safety instructions to hand.

1.2 Safety symbols used and their meanings



Hazard to life and health if the safety instructions are not followed.



If the safety instructions are not followed, there is a possibly hazardous situation that can result in injury or material damage.



This symbol indicates important information for correctly handling the machine. Ignoring these instructions can result in problems on the machine or the surrounding area.

1.3 Notes on safety for persons and the machine



Never put fingers, your face, hair or other parts of the body, or loose, wide items of clothing into the operating and intake areas of rotating parts (workpiece, clamping chuck, centring chuck). Do not wear jewellery (rings, chains etc.). Risk of injury and accidents!



Only use machines that operate faultlessly. If the machine is so heavily damaged (cracks, deformation etc.) that electrical or drive parts are exposed, pull out the mains plug immediately and contact Customer Service. Maintenance and repair work may only be carried out by specialist workshops authorised by Rothenberger. Incorrect repairs can present significant hazards for the user!



In the event of faults (unusual smell, vibrations, unusual noises) during work with the SUPERTRONIC, it is essential to immediately press the safety pedal and perform an EMERGENCY STOP of the machine!



If the machine is running, it is prohibited to hold the workpieces manually or to perform similar work, and to fit and remove parts such as filters, valves, pipe sections etc!



Only persons who have been instructed on how to operate the machine may carry out work listed in Chapter 1.1 "Correct use"!



Never operate the machine when tired or when under the influence of alcohol, medicines or drugs!



Wear safety clothing!

Wear a safety mask to provide protection against splashes of thread-tapping oil as well as any chlorine gas vapours (from thread-tapping oil burning on hot tool and workpiece surfaces)!

Wear a safety hat to cover and protect long hair.

Wear safety gloves when changing the thread-tapping jaws, the pipe cutting wheel and the pipe deburrer.

Wear safety gloves when changing the tool and workpiece. The thread and thread cutting jaws get hot during thread-tapping!

Wear safety footwear. Risk of injury (slipping) on any escaping thread-tapping oil! Risk of injury from wet, slippery and possibly off-centre machine parts when changing the tool!



Do not remove metal and plastic chips using compressed air! There is a risk of eye injuries and loss of eyesight!



Keep the working area clean and orderly. Disorder at the workplace increases the risk of accidents and injuries!



Remove hand tools from the machine before switching it on! Risk of accidents and injury!



Take account of ambient influences! Ensure that the lighting is good! Do not leave electrical tools out in the rain! Do not use electrical tools in a damp or wet environment! Risk of electric shock!



Do not use electrical tools near flammable liquids or gases. Risk of detonation and explosion!



Ensure sufficient ventilation during indoor use (closed rooms).
The permissible ambient temperature is between 0°C and 40°C!



Keep tools in a safe place! When they are not being used, store tools in a dry, locked room so that they are not accessible to children!



Do not allow any persons who are not employed by the company or un instructed persons to operate / touch the machine and tools or the mains power cable!



If the machine is not to be used for some time, it is essential to switch it off and to pull out the mains cable!



Before changing the cutting heads, the cutting wheel, the pipe deburrer, always switch off the machine and pull out the mains plug (de-energised operation!)

After it has been switched off, the machine still coasts for a while until it comes to a standstill.

Do not touch any parts before the machine is completely stationary and the mains plug has been pulled out!



If the machine is being cleaned, maintained, inspected or repaired , it is essential to switch it off and to pull out the mains plug (de-energised operation)!

Always avoid uncontrolled starting-up of the machine. Risk of injury and accidents!



Before setting up the thread-tapping machine, read these operating instructions through carefully and in full. You must fully understand the warnings, instructions and lists they contain concerning fault-free, safe operation and operating the machine, as well as those relating to your safety!



Keep the operating instructions in a clean, dry place and within easy reach. If the used machine is sold, European regulations dictate that these operating instructions must always be given to the purchaser!



In the case of the threaded pipes, carry out a pressure test in order to ensure that no gas or water can escape after the pipes are fitted!

2. Technical data

2.1 Technical data SUPERTRONIC 2 SE

Art.-No. 05.6120	SUPERTRONIC 2 SE, 110 V
Art.-No. 05.6125	SUPERTRONIC 2 SE AUTO, 110 V
Art.-No. 05.6150	SUPERTRONIC 2 SE, 230 V
Art.-No. 05.6175	SUPERTRONIC 2 SE AUTO, 230 V
Cutting capacity:	BSPT R 1/4" ... 2", NPT 1/4" ... 2", bolt thread 3/8" ... 2"
Speed:	40 rpm under no load
Motor:	Single-phase universal motor 1150 W, overload protection
Protection class:	I
Frequency:	50/60 Hz
Weight:	44 kg (without accessories)
Dimensions:	535 x 430 x 340 mm (LxWxH)
Thread-tapping head:	Standard tapping head 1/2" ... 2" Automatic tapping head 1/2" ... 2"
Thread jaws:	1/2" ... 3/4", 1" ... 2"

2.1 Technical data SUPERTRONIC 3 SE

Art.-No. 05.6253	SUPERTRONIC 3 SE, 110 V
Art.-No. 05.6254	SUPERTRONIC 3 SE AUTO, 110 V
Art.-No. 05.6250	SUPERTRONIC 3 SE, 230 V
Art.-No. 05.6255	SUPERTRONIC 3 SE AUTO, 230 V
Cutting capacity:	BSPT R 1/4" ... 3", NPT 1/4" ... 3", bolt thread 3/8" ... 2"
Speed:	33 rpm under no load
Motor:	Single-phase universal motor 1700 W, overload protection
Protection class:	I
Frequency:	50/60 Hz
Weight:	74 kg (without accessories)
Dimensions:	650 x 480 x 420 mm (LxWxH)
Thread-tapping head:	Standard tapping head 1/2" ... 2" and 2" ... 3" Automatic tapping head 1/2" ... 2" and 2 1/2" ... 3"
Thread jaws:	1/2" ... 3/4", 1" ... 2", 2 1/2" ... 3"

2.1 Technical data SUPERTRONIC 4 SE

Art.-No. 05.6470	SUPERTRONIC 4 SE, 110 V
Art.-No. 05.6475	SUPERTRONIC 4 SE AUTO, 110 V
Art.-No. 05.6460	SUPERTRONIC 4 SE, 230 V
Art.-No. 05.6465	SUPERTRONIC 4 SE AUTO, 230 V
Cutting capacity:	BSPT R 1/4" ... 4", NPT 1/4" ... 4", bolt thread 3/8" ... 2"
Speed:	22/50 rpm under no load
Motor:	Single-phase universal motor 1750 W, overload protection
Protection class:	I
Frequency:	50/60 Hz
Weight:	105 kg (without accessories)
Dimensions:	750 x 540 x 480 mm (LxWxH)
Thread-tapping head:	Standard tapping head 1/2" ... 2", 2" ... 3", 3.12" ... 4" Automatic tapping head 1/2" ... 2" and 2 1/2" ... 4"
Thread jaws:	1/2" ... 3/4", 1" ... 2", 2 1/2" ... 4"

3 Functions of the thread-tapping machine

3.1 Overview / accessories / description

3.1.1 Overview, thread-tapping machine

Overview, control elements (> see front fold-out page):

1 Pipe cutter	7a Overload protection switch for machines with pedal
2 Thread-tapping jaws	7b On / Off switch for machines without pedal
3 Internal deburrer	8 Centring chuck
4 Tool carriage	9 Clamping chuck
5 Oil drainage screw	10 Thread-tapping head
6 Feeder hand wheel	

3.1.2 Overview, automatic thread-tapping heads 2 SE and 3 SE

Overview, control elements (> see front fold-out page):

11 T-handle	16 Profile pin
12 Selector pin (silver)	17 Locking lever, body
13 Selector pin (black)	18 Locking lever, clamping head
14 Threaded pin (fast adjustment)	19 Cam plate
15 Profile body	20 Selector block

3.1.3 Accessories



Use only suitable accessories recommended by ROTHENBERGER Werkzeuge GmbH!

GB

Standard tapping head

alternatively
Automatic tapping head

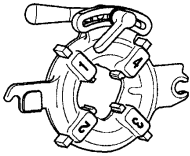

Pipe stand

Height-adjustable, with ball guide,
for pipes up to 6"



NIPPEL MAX

For internally clamping
short pipe sections
manufacturing
nipples and double nipples
size 1/2" ... 2",
Recycling pipe waste pieces
saves time and money
automatic fast clamping
and centring of the
pipe pieces for right-hand
and left-hand thread
for fast, rational working,
automatic release after
completion of the nipple,
hardened, ground
clamping jaws

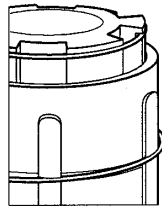
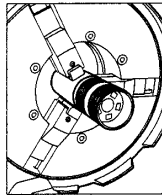
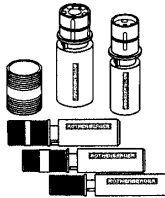

- NIPPEL MAX-Set,
complete in sheet
steel carrying case
1/2" • 3/4" • 1" • 1 1/4"
• 1 1/2"
- Nipple holder
1/2" • 3/4" • 1" • 1 1/4" • 1 1/2" • 2"
- Sheet steel case
- Plastic inlay

Spare cutting wheel

D=41 mm, L=19 mm, DA=9 mm
hardened special steel for
machine type
- PANDA 40, PANDA 90
- PISET 3 SG, No. 6
- SUPERTRONIC 2S, 3S, 4S, 2SE,
3SE, 4SE



RONOL SYN

High-performance thread-tapping fluid
mineral oil-free, synthetic-based specially
developed and approved for drinking
water and sanitary installation.
100 % water-soluble, physiologically
harmless.
- in 5-litre plastic canisters

RONOL

High-performance thread-tapping fluid
mineral oil-based, very well suited
for thread-tapping work on all
materials including stainless steel.
- in 5-litre plastic canisters

3.1.4 Functional description

Threads are cut or turned on workpieces such as pipes or rods in the thread-tapping machine SUPERTRONIC 2 SE, 3 SE and 4 SE.

The machine consists of:

- a drive motor that rotates the centring chuck (8)
- a clamping chuck (9) for securing the workpiece
- a pipe cutter (1) for cutting the workpiece to length
- an internal deburrer (3)
- a thread-tapping head (10) for making a thread on the workpiece
- an oil pump that lubricates and cools with thread-tapping oil
- a tool carriage (4) guided on both sides with a toothed feed
- a chip collecting and oil trough
- a safety pedal
- a coasting restrictor

4 Preparations for operation

4.1 Scope of delivery

When you receive the machine, check

- that it corresponds to the specifications outlined in your order
- for damage or deformation attributable to accidents or other causes during transport
- that all the ordered articles and accessory parts have been supplied.

If you find any deviations, contact the company that sold you the machine immediately or our sales office.

4.2 Transporting the thread-tapping machine



Bend at the knees when lifting the machine so as to protect your back against over-stressing.

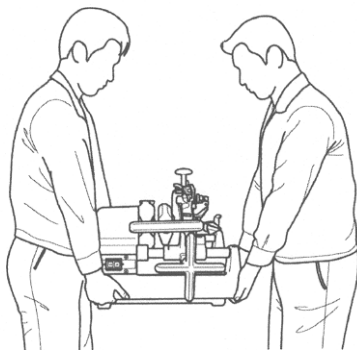



Fix the tool carriage so that it cannot move while the machine is being transported. Hold the machine securely by its base to lift it. Do not hold the machine by its centring chuck or the internal deburrer when carrying it!



If the machine is transported with the thread-tapping oil still inside, the oil might splash out onto clothing due to vibrations!



Thread-tapping oil on the surface of the machine makes it slippery. Ensure that it does not slip out of your hands when you lift it!

4.3 Setting up the machine



Set up the machine in a dry location!

Place the machine on a level surface without spaces or on a flat work bench. The centring chuck must be higher in relation to other parts of the machine so that no thread-tapping oil can escape via the pipe being machined and contaminate the floor!

Centring chuck side

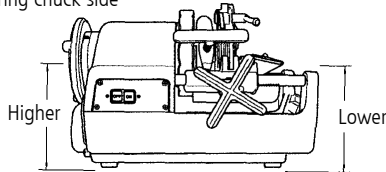

Ensure that there is sufficient space around the machine and in the working area!



If you do not have a clear view of the dangerous area formed by the machine and the revolving workpiece, the full length of the revolving workpieces must be reduced or the dangerous area must be safeguarded by a cordon or warning signs!

The safety fixtures must be set up and secured firmly. If supports are used for this purpose, they must be height-adjustable and sturdy and there must be a sufficient number of them!

4.4 Electrical connection



Do not place either the machine or workpieces on the connecting cable, otherwise the cable could be damaged and electrical current could be exposed, presenting an electric shock hazard!



Never touch the mains plug and mains cable with wet hands. Electric shock hazard!



When connecting the machine to the electricity supply, always ensure that the switch (7) is set to "OFF", otherwise there is a risk that the machine will start up unnoticed and unsupervised when the power is connected!

Risk of injury and accidents!



The power source must be fitted with a residual current-operated circuit breaker so that electric shocks can be prevented!



It is essential that the voltage on the machine's rating plate corresponds to the power source, otherwise the machine could get hot, smoke could develop, start a fire and cause damage!



Protection against electric shock:
The machine has protection class I. Additional earthing is not necessary!



The integrated overload protection automatically stops the machine in the event of an overload or power fluctuations! Switching back on is not possible until one minute has elapsed!



Use the extension cable H07 RN 3 x 1.5 mm²! The cable should not be longer than 30 m!

4.5 The thread-tapping oil



For tapping, use ROTHENBERGER high-performance thread-tapping oil art. no. 6.5010. This oil is **not suitable** for tapping **drinking water pipes**!



Alternatively, you can use ROTHENBERGER high-performance thread-tapping fluid, art. no. 6.5015. This fluid is **suitable** for tapping all pipelines (including drinking water pipelines).



Keep thread-tapping oils out of the reach of children!



Do not thin thread-tapping oil or mix it with other oils! If the thread-tapping oil becomes mixed with water, it turns milky-white, its quality is reduced and the tapped thread displays lower quality. It is then recommended to change the oil!

Avoid direct sunlight and store the oil in a dark place!

Close the oil container tight after use in order to prevent the ingress of dirt and water!



ATTENTION PERSONS WITH ALLERGIES!

Thread-tapping oil that lands on the skin can cause skin irritation, inflammation and allergic reactions!

When handling oil, wear protective clothing and cover exposed skin areas.

If your skin comes into contact with oil, wash it immediately with tap water and soap. If thread-tapping oil burns onto hot workpiece or tool surfaces, this can produce toxic vapours or gases (e.g. chlorine gas when red oil burns). If you have accidentally inhaled this oil mist or oil vapours, go out into the fresh air immediately and consult a doctor without delay!

4.6 Checking the thread-tapping oil



When cleaning, servicing, inspecting or repairing the machine, it is essential to switch it off and pull out the mains plug (de-energised operation)!

- A new machine or a machine that has not been used for an extended period is covered with an oil film to protect it. Remove this with a clean cloth.
- Turn the rotary handle (6) anti-clockwise in order to move the tool carriage (4) to the clamping chuck (9).
- On the right side of the machine, fill up with the supplied thread-tapping oil to the level of the sieve mesh.

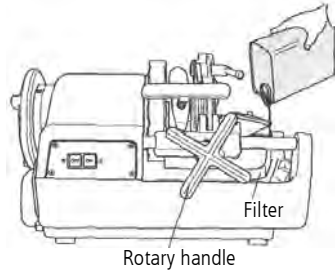

- Ensure that the machine is still switched off and insert the mains plug back into the socket.
- Switch on the machine and ensure that the thread-tapping oil runs out of the thread-tapping head to the cutting jaws. If the right amount of oil is not supplied, regulate it with the oil adjustment screw.

4.7 Setting the supplied thread-tapping oil quantity



When cleaning, servicing, inspecting or repairing the machine, it is essential to switch it off and pull out the mains plug (de-energised operation)!

- Ensure that the oil tank is filled with oil up to the level of the sieve mesh.
- If the amount of thread-tapping oil running via the thread-tapping head does not meet the requirements, the supplied amount must be adjusted with the aid of the oil adjustment screw.
- Undo the locking nut of the oil adjustment screw.

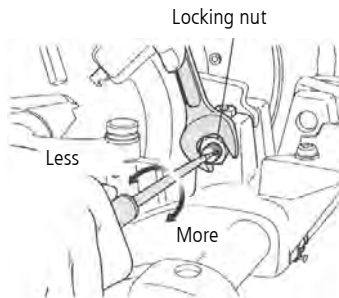

- Turning the oil adjustment screw clockwise increases the amount of oil delivered and turning it anti-clockwise reduces the amount.
- Tighten the locking nut firmly after making the adjustment.

4.8 Draining off the oil



It is essential to also observe the safety and disposal regulations in Chapter 8!

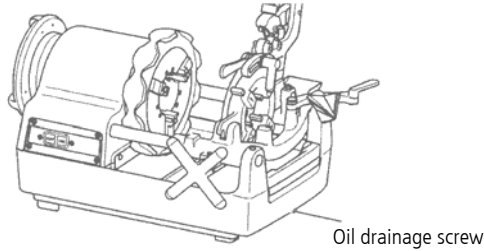

5 Operation of the thread-tapping machine

5.1 Clamping the workpieces



The tool carriage can make contact with the frame before the tapping process has ended and the clamping chuck and the machine can be damaged as a result!

A clearance of at least 70 mm must therefore be maintained between the thread cut on the workpiece and the clamping chuck!

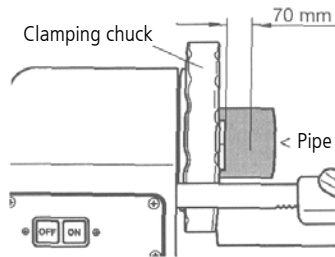

- Move the pipe cutter (1) and the thread-tapping head (10) up so that they are not in the way and position the internal deburrer (3) on the rear side.
- Insert the workpiece from the centring chuck side (8) and tighten the centring chuck.

Centring chuck

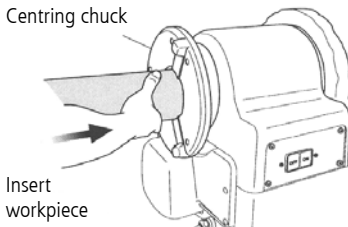

Tighten centring chuck

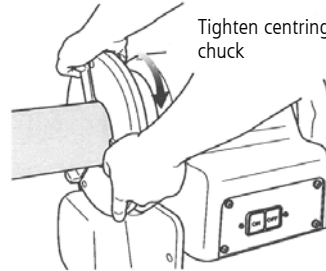

In the case of long or heavy pipes, it is essential to use the pipe support Art. No. 5.6047 in order to prevent the workpiece wobbling or twisting while it is being turned and to prevent the machine from tipping over due to the weight of the workpiece! Otherwise, the workpiece and the machine can become unstable. Make safe the danger area as described in Chapter 4.3!

- Hold the workpiece on the clamping chuck side (9) securely with your right hand and gradually tighten it with the clamping chuck.

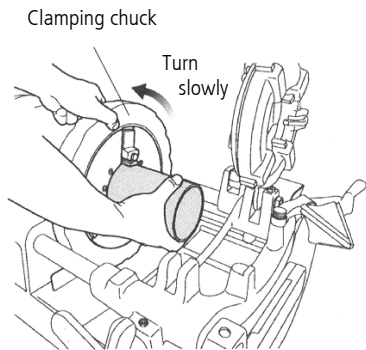

Hold workpiece tightly with your right hand

- Ensure that the three clamping jaws are in contact with the workpiece.
- If the three clamping jaws are not in contact with the workpiece, it will wobble and neither cutting nor thread-tapping can be performed correctly.
- Clamp the workpiece securely and tighten it very firmly.

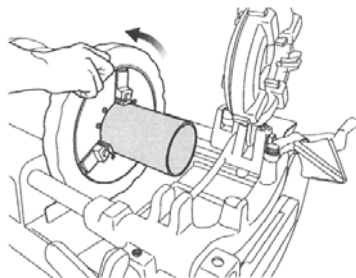

Turn the clamping chuck securely

5.2 Cutting the workpiece with the pipe cutter (1)



**Do not touch the cutting surface with bare hands, because it is hot and has sharp edges!
Risk of injury and burning!**



If the handle of the pipe cutter (1) is turned with force, the cutting surface of the pipe takes an oval shape, which makes correct thread-tapping impossible. Therefore, move the handle of the pipe cutter half a turn per whole pipe rotation!

- Move the pipe cutter (1) up so that it is not in the way. Turn the feeder hand wheel (6) anti-clockwise in order to bring the pipe cutter into the position necessary for cutting the workpiece.

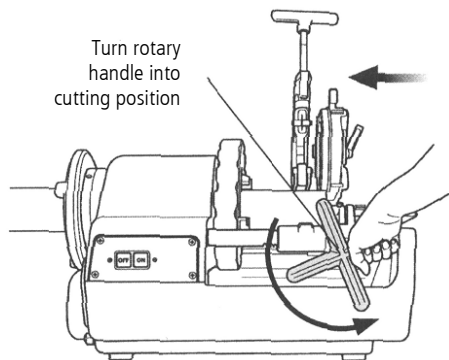

- Move the pipe cutter down onto the workpiece and then press the ON switch (7) or press the pedal.
- Turn the handle of the pipe cutter powerfully clockwise and start to cut the workpiece.

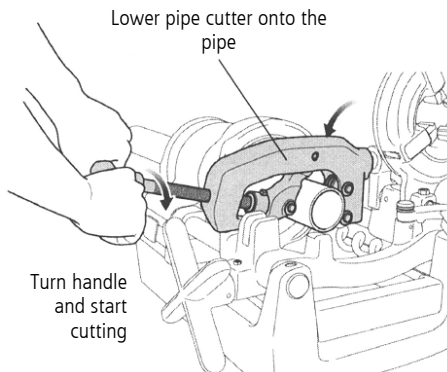

- Swivel the pipe cutter down and back again.
- Do not collect the cut pipes in the trough! Take them out of the trough immediately after the cutting process ends!

5.3 Reaming the workpieces



**The cutting tip of the internal deburrer (1) is very sharp! Do not touch it with bare hands!
Risk of cutting and injury!**

- Ream the complete inner surface of the pipe cut with the pipe cutter (1).
- Pull the internal deburrer (3) towards you and insert a pipe if there is not already one in the machine before separation.

- Turn the feeder hand wheel (6) anti-clockwise and gently press the cutting edge of the reamer against the inside of the pipe in order to ream.
- Turn the rotary handle further and gently press the cutting edge of the reamer against the inside of the pipe in order to ream.

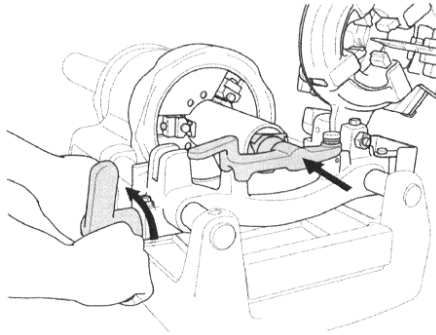

5.4 Changing the thread size

5.4.1 Thread-tapping machine SUPERTRONIC 2 SE

The thread jaws $\frac{1}{2}$ " ... $\frac{3}{4}$ " must be used for thread sizes $\frac{1}{2}$ " and $\frac{3}{4}$ ".

The thread jaws 1" ... 2" must be used for pipe sizes 1, 1 $\frac{1}{4}$ ", 1 $\frac{1}{2}$ " and 2".

To change the thread sizes from $\frac{1}{2}$ " and $\frac{3}{4}$ " to 1", 1 $\frac{1}{4}$ ", 1 $\frac{1}{2}$ " and 2" and vice versa, the thread jaws in the thread-tapping head (10) must also be changed as described in the following chapters.

5.4.2 Thread-tapping machine SUPERTRONIC 3 SE / 4 SE

The thread jaws $\frac{1}{2}$ " ... $\frac{3}{4}$ " must be used for thread sizes $\frac{1}{2}$ " and $\frac{3}{4}$ ".

The thread jaws 1" ... 2" must be used for pipe sizes 1, 1 $\frac{1}{4}$ ", 1 $\frac{1}{2}$ " and 2".

The thread jaws 2 $\frac{1}{2}$ " ... 3" must be used for thread sizes 2 $\frac{1}{2}$ " and 3".

The thread jaws 2 $\frac{1}{2}$ " ... 4" must be used for thread sizes 2 $\frac{1}{2}$ " and 4".

To change the thread sizes from $\frac{1}{2}$ " and $\frac{3}{4}$ " to 1", 1 $\frac{1}{4}$ ", 1 $\frac{1}{2}$ " and 2" and vice versa, and to change the thread sizes from $\frac{1}{2}$ ", $\frac{3}{4}$ ", 1", 1 $\frac{1}{4}$ ", 1 $\frac{1}{2}$ " and 2" to 2 $\frac{1}{2}$ " and 3" and vice versa, the thread jaws in the thread-tapping head (10) must also be changed as described in the following chapters.

5.5 Removing and installing the thread jaws from and in the thread-tapping head (10) in the tool carriage (4)

5.5.1 Automatic thread-tapping head

Removal:



Wear gloves in order to prevent cut injuries to the hands caused by the thread jaws!

- Pull the parking lever into the "A" position in order to open the thread jaws.

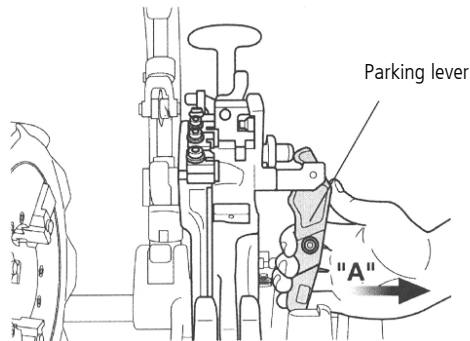

- Insert the selector pin (silver colour) into the selector block of the thread jaws.

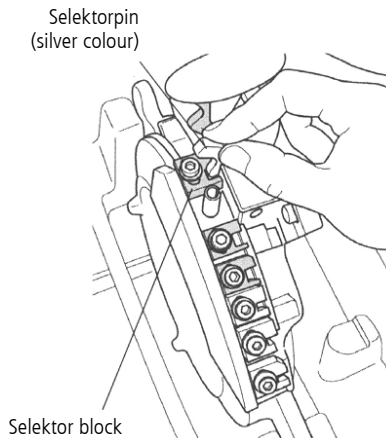

- Pull the thread jaws No. 1 and 4 up and out when the thread-tapping head is in the lower position.
- Lift out the thread-tapping head (10) and pull the thread jaws No. 2 and 3 down.

Installation:



Precise thread-tapping is only possible if the number on the slot of the thread-tapping head corresponds with the number on the thread jaw!

- Pull the parking lever in the "A" direction in order to open the thread jaws.

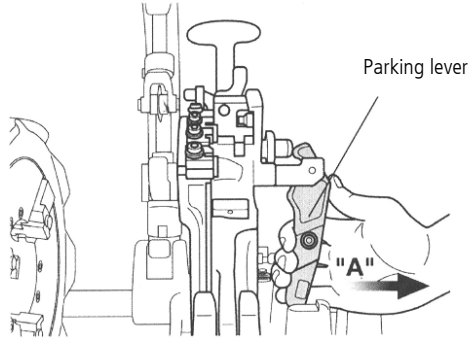

- Insert the selector pin (silver colour) into the selector block of the thread jaws.

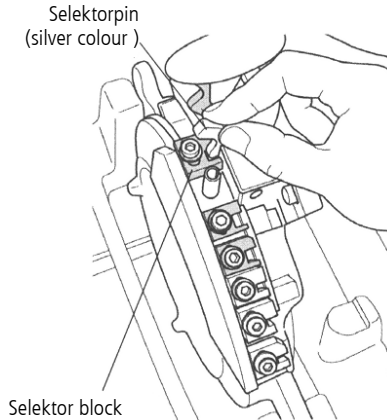

- Insert the thread jaws with the same number as on the respective thread-tapping head (10) and make sure it engages audibly.
- Ensure that the numbers on the thread-tapping head and on the thread jaws are on the same side.

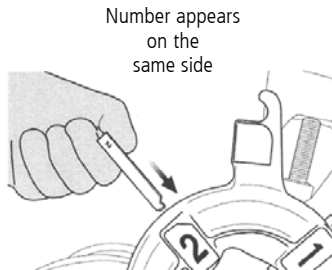

5.5.2 Standard thread-tapping head

Removal:



Wear protective gloves in order to prevent hand injuries caused by the thread jaws!

- Release the die holder, bring the cradle into the lowest position, tighten the die and move the opening and closing lever up to remove the thread jaws.

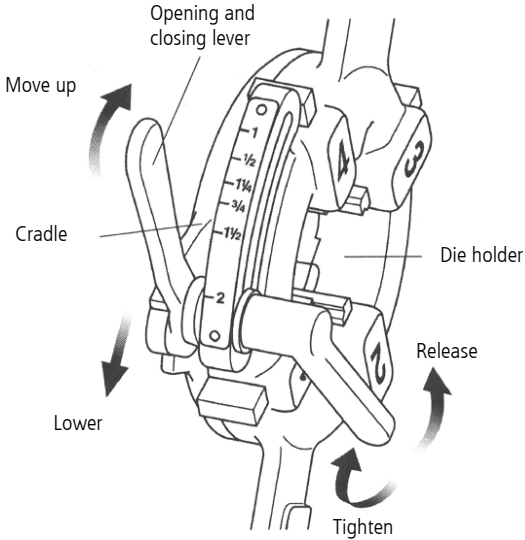

- Pull the thread jaws No. 1 and 4 up and out when the thread-tapping head (10) is in the lower position.
- Lift out the thread-tapping head and pull the thread jaws No. 2 and 3 down and off.

Installation:



Precise thread-tapping is only possible if the number on the slot of the thread-tapping head corresponds with the number on the thread jaw!

- Release the die holder, bring the cradle into the lowest position, tighten the die and move the opening and closing lever up to remove the thread jaws.
- Insert the thread jaws with the same number as on the respective thread-tapping head (10) and make sure it engages audibly.
- Ensure that the numbers on the thread-tapping head and on the thread jaws are on the same side.

5.6 Changing the complete thread jaws and the thread-tapping head

Installing and removing the thread-tapping head (10) into and out of the bed carriage:

- Lift the thread-tapping head to half height.
- Bring the thread-tapping head into the diagonal position and remove it.
- Not until the thread-tapping head is in a parallel position to the flat side of the thread-tapping pin can it be removed from or installed in the machine.

Changing the thread-tapping head

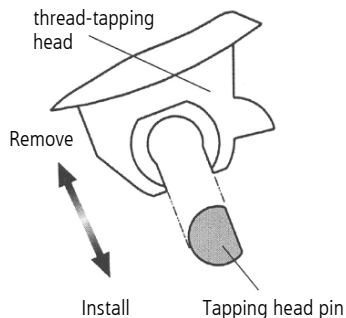
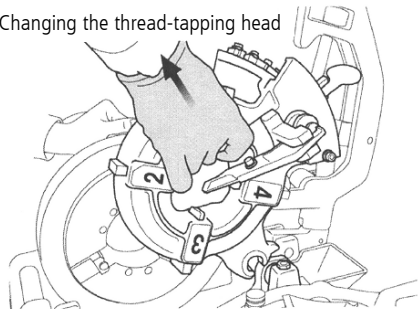

5.7 Changing the thread size

Automatic thread-tapping head:

- Ensure that the thread-tapping head (10) is on the tool carriage and that the thread jaws correspond to the thread size.
- Insert the selector pin into the selector block with the necessary thread size.

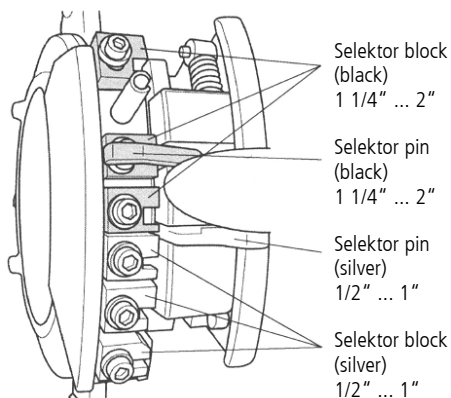

- The size is shown on the respective selector block.
Use the silver selector pin and the block for 1/2" ... 1" and the black selector pins for 1 1/4" ... 2".

For the standard thread-tapping head:

- After releasing the pipe cutter (1), the cradle can be moved up and down.
- Balance the reading-off device on the cradle with the defined measuring division on the scale plate.

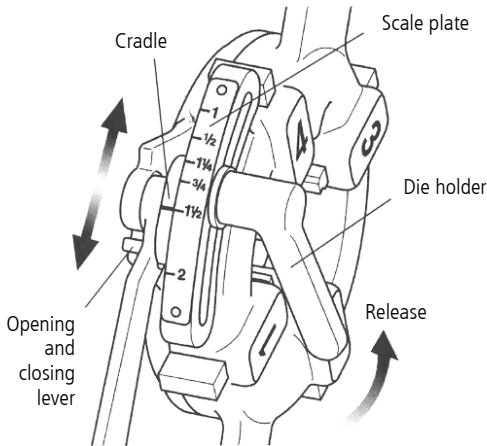

**After changing the thread-tapping jaws, check that they are secure!
After changing the thread-tapping head or replacing the thread-tapping jaws, check that they are locked securely in the tool carriage!**

5.8 Tapping threads



**To protect your hands, the thread-tapping machine is fitted with a safety pedal!
The safety pedal has an Emergency Stop switch function!**

- If there is a dangerous situation, press the safety pedal right down. This stops the machine.
- To restart the machine, press the release button on the side of the safety pedal.



Be careful that you do not crush your hands when lowering the thread-tapping head!



Do not use force when working on the machine so that the motor cannot come to a standstill because of an overload, for example caused by worn thread jaws!



Use only raw material that is in perfect condition for tapping threads.
If you use deformed and / or pipes cut off at an angle, it is not possible to tap threads that conform to the relevant standards!



To guarantee precisely ground threads, follow the instructions below:

Use the thread-tapping head and the corresponding thread-tapping jaws that matches the thread size! **Secure the thread-tapping head correctly on the tool carriage.**

Do not place the thread-tapping head directly and unprotected on the floor and handle it with care!
Ensure that the thread-tapping oil runs on the thread-tapping jaws!

For the automatic thread-tapping head:

- Lower the thread-tapping head and insert the T handle, pressing in fully in the "B" direction until the thread-tapping jaws engage in the working position

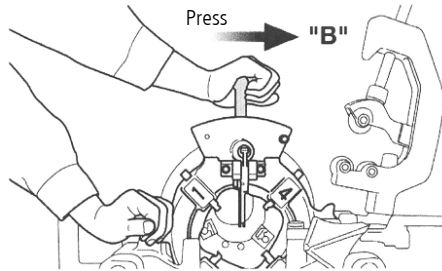

- Switch on the machine with the pedal, turn the rotary handle anti-clockwise so that the thread jaws press onto the workpiece.
- Release the rotary handle when 2 to 3 thread turns are cut.

Rotate the rotary handle to cut 2 to 3 thread turns

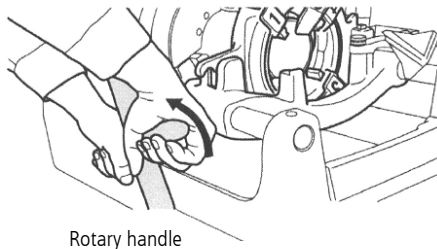

- The thread-tapping jaws open automatically via a longitudinal stop lever when the thread has been fully cut.
- Switch off the machine by taking your foot off the safety pedal.

For the standard thread-tapping head:

- Lower the thread-tapping head and move the opening and closing lever down towards you.
- Switch on the machine with the pedal, turn the rotary handle clockwise so that the thread jaws press on the workpiece.
- Release the rotary handle when two to three threads have been cut.
- With the machine running, slowly move the opening and closing lever up when the required number of threads has been cut, so as to end the cutting process by slowly opening the thread jaws.



If the thread jaws are opened jerkily, steps can be created in the last section of the thread, with the result that the thread is faulty!

5.9 Setting the thread length (only Automatic thread-tapping head)

The thread length was set by the manufacturer but can be changed if required.

- Turn the parking handle in the "C" direction until it engages.
- Release the block screw and move the parking lever to adjust the thread length. For a longer thread, push it in the "D" direction and for a shorter thread push it in the "E" direction. The thread length can be changed by approximately 2 mm per scale division.

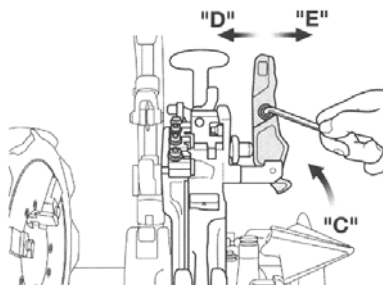

- Gently tighten the block screw and bring the parking lever into the starting position by pushing the profile pin in the "F" direction.

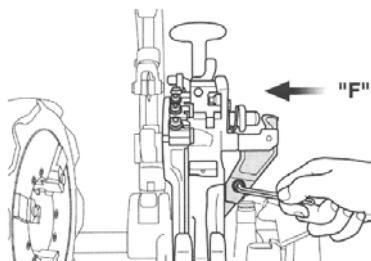

- Then tighten the screw to lock the parking lever.

5.10 Setting the thread depth (only automatic thread-tapping head)

5.10.1 Only thread-tapping machine SUPERTRONIC 2 SE

- Undo the block screw with which the selector block is secured on the cam plate.
- Move the selector block to adjust the thread depth.
- For a deeper thread, push in the "H" direction and for a flatter thread push in the "G" direction. The thread depth can be changed down or up by 1.5 to 2 mm per scale division.

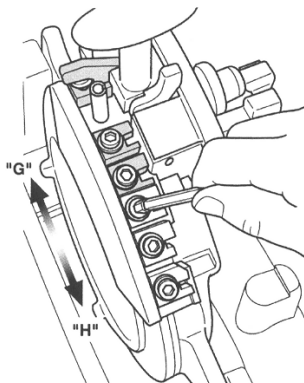

- Fix the selector block by tightening the block screw and start cutting the thread.
- With the aid of a measuring instrument, check the cut pipe for a tapered thread etc. and correct the setting if necessary.

5.10.2 Thread-tapping machine SUPERTRONIC 3 SE / 4 SE

- Undo the block screw and move the selector block to adjust the thread depth.
- For a deeper thread, push in the "H" direction and for a flatter thread push in the "G" direction. The thread depth can be changed down or up by 1.5 to 2 mm per scale division.

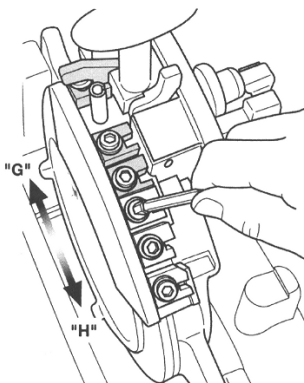

5.11 Thread-tapping in 2 work steps (only automatic thread-tapping head 2 ½" ... 3" / 4")

- To tap a thread on a pipe with a large diameter with low tension, first use the 2-step thread-tapping pin (black) for thread-tapping (pre-tapping) and then the selector pin (silver) for tapping (post-tapping) standard threads.

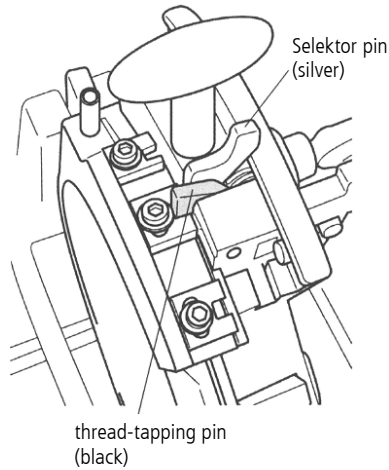

5.12 Removing the workpiece



The workpiece is damp and slippery from the thread-tapping oil. Carefully ensure that it does not slip out of your hands and drop onto your feet when you remove it from the machine!

- Turn the feeder hand wheel (6) clockwise and move back the tool carriage (4).
- Release the clamping chuck.
- Release the centring chuck and pull out the workpiece.

5.13 Cleaning after use



Do not remove metal and plastic chips using compressed air!
There is a risk of eye injuries and loss of eyesight!
Do not pick up sharp-edged metal chips with your bare hands!
Risk of injury! Wear protective gloves!

- Remove chips from on and around the machine.
- Use a wire brush to remove chips from and clean the clamping chuck, the thread-tapping jaws of the thread-tapping head and the internal deburrer.
- Use a cloth to wipe thread-tapping oil splashes from the machine and the workplace.

6 Maintenance and inspection

All machines are subject to natural wear during use. They must be maintained from time to time and wear parts must be replaced.

This work may only be carried out by an authorised ROTHENBERGER service station. This gives you a full warranty on the material and workmanship!

GB



If the machine is being cleaned, maintained, inspected or repaired, it is essential to switch it off and to pull out the mains plug (de-energised operation)! Always avoid uncontrolled starting-up of the machine. Risk of injury and accidents!

6.1 Changing the internal deburrer blade



Always wear protective gloves when replacing the blades! Risk of cuts and injury!

- Lift the pipe cutter and the thread-tapping head and pull the internal deburrer towards you.
- Remove the spring pin out of the next of the reamer blade.
- The reamer blade is released when you pull the reamer blade holder forwards.
- Fit a new reamer blade.
- Put the previously removed spring pin back into the hole of the new reamer blade.

6.2 Changing the pipe cutter cutting wheel



Always wear protective gloves when replacing the blades! Risk of cuts and injury!

- Bring the pipe cutter into an upright position and lower the thread-tapping head.
- Pull off the cotter pin upwards.

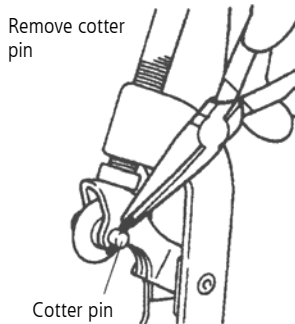

- Hold the cutting wheel and push the cutting wheel straight pin slowly out on the opposite side.

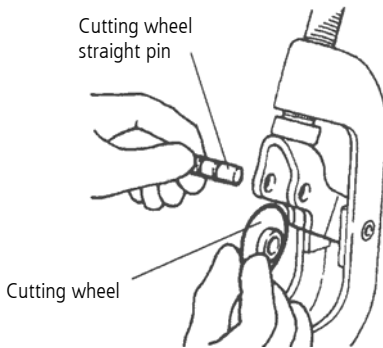

- Remove chips, dirt, oil etc. from the pin and grease the groove.
- Insert a new cutting wheel into the blade holder and insert the pin again.
- Insert a new cotter pin into the cutting wheel straight pin and secure it by bending it apart.

6.3 Changing the clamping jaw inserts

- Turn the feeder hand wheel clockwise so that the tool carriage moves to the right end.
- Bring the pipe cutter into an upright position so that it is not in the way.
- Turn the clamping chuck and open it until a screwdriver (2 SE) or an Allan key (3 SE) fits inside.

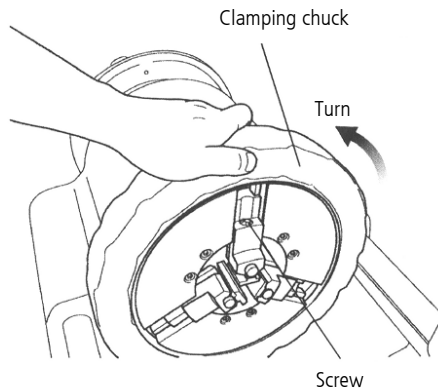

- Undo the screws that secure the clamping jaw inserts.

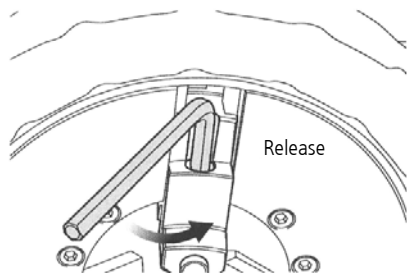

- Place a thin rod onto the upper edge of the spring and pull out the clamping chuck pin.

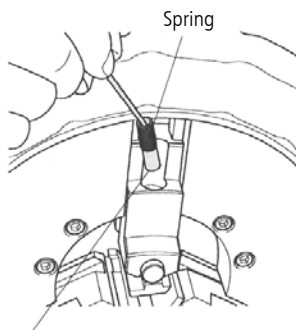

Clamping chuck pin

- Pull the clamping jaw insert forward.

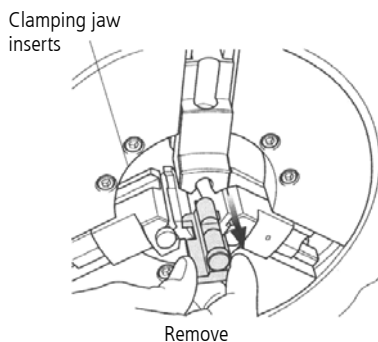

- Remove the other two clamping jaw inserts if three clamping jaw inserts must be replaced at the same time.
- Remove chips, dirt, oil etc. from mounting surface of the clamping jaw inserts.
- Insert a new clamping jaw insert and push it right to the back, replace the spring and the clamping chuck pin. Tighten the screw.
- Install the two other clamping jaw inserts in the same way.

6.4 Daily inspection

- Check the mains plug, mains cable and extension cable to ensure they are undamaged.
- Correctly filled oil trough
- Adjust the oil screw if necessary
- Clean the oil tank if there are impurities in it.
- Inspect the thread-tapping jaws, pipe cutter and internal deburrer for any wear and replace parts if there is wear.
- Clean the clamping jaws with a wire brush if they are dirty.
- Check that the dowel screws are secure. Tighten if necessary.
- Remove dirt and chips from the machine regularly.
- Apply anti-rust grease if the machine is not going to be used for an extended period.
- Lubrication of spindle support:
The rear spindle support has to be lubricated periodically.

Attention! Before starting the lubrication-works the power plug has to be taken out of the power source.

The lubrication is only allowed for persons which have been supervised in electrical safety issues.

7 Troubleshooting

Fault

Inspection / remedy

If no oil comes out ...

Is the oil tank still full?
Are the suction line, filter and sieve free?
Is the pump in order?

If the power supply is insufficient ...

Has the voltage also dropped?
Is the extension cable of the correct dimensions? (also see Chapter 4.4)

Machine stops and will not start again ...

Due to an overload or power fluctuations, the integrated overload protection facility has automatically stopped the machine. Switching back on is possible after 1 minute has expired.

If the thread has not been cut in the normal way ...

Is the thread-tapping oil also contaminated or dirty?
Have the thread-tapping jaws become worn?
Is the cut pipe end also not angled?

If thread-tapping does not function at all ...

Are the thread-tapping jaws of the right size?
Do the numbers on the thread-tapping jaws also correspond to those on the thread-tapping head?
Has the correct size thread-tapping head been selected??

8 Disposal

8.1 Metal, electrical and electronic parts

Parts of the unit are valuable materials and can be recycled. Approved and certified recycling companies exist for this purpose. Metals must be sorted and delivered separately to a disposal company.

Please consult your responsible refuse disposal authority for how to dispose of unusable parts in an environmentally responsible way (e.g. electronic scrap):

8.2 Oils and lubricants

Only specialist companies are authorised to dispose of old oils.

Old oils and contaminated oils must be stored and disposed of in sealed, oil-resistant containers (metal drums).

Defective electrical appliances and machines that cannot be repaired must be opened and cleaned to remove the remaining oil.

Oil troughs must be cleaned so that there are no traces of oil. No oils (even very small amounts) may be allowed to enter the ground

8.3 Waste from maintenance work

Regulations issued by the responsible national and regional authorities for disposing of refuse must be observed. These are available from the local environmental authority.

If in doubt, waste from maintenance work such as cleaning and rinsing agents, cloths etc. must be disposed of as special category waste by communal collecting points.

Waste that can be recycled must be separated on the basis of material groups and sent for suitable recycling!

9 Warranty

The warranty for the ROTHENBERGER thread-tapping machine SUPERTRONIC 2 SE, 3 SE and 4 SE takes the form of a contractual agreement. The warranty covers the free remedying of all faults or defects on the machine that have occurred within the warranty period and that can be proven to be attributable to material or manufacturing errors. The warranty does not cover damage or defects arising from incorrect connection, incorrect handling and non-observance of the operating instructions and the safety instructions for electrical tools. Damage caused by natural wear, incorrect handling or use, non-observance of the operating instructions, unsuitable equipment, excessive stress, use for the wrong purpose, unauthorised interference or other reasons not attributable to ROTHENBERGER are not covered by the warranty. There shall also be no warranty cover for damage caused by using spare parts other than original ROTHENBERGER parts. The warranty shall also be void if the machine is opened by unauthorised persons before the warranty period expires. Replaced parts become our property. In some countries, delivery fees may be charged. These terms do not affect statutory warranty claims

10 Customer service

The Rothenberger service locations or else the manufacturer with his repair department are available to help you. Needless to say, we will also send you spare parts at short notice. Please contact please your retailer or the manufacturer.

Order your accessories and spare parts from your specialist retailer or using our after-sales hotline:

Phone: +49 (0) 6195 99 52 14

Fax: +49 (0) 6195 99 52 15