

USER GUIDE

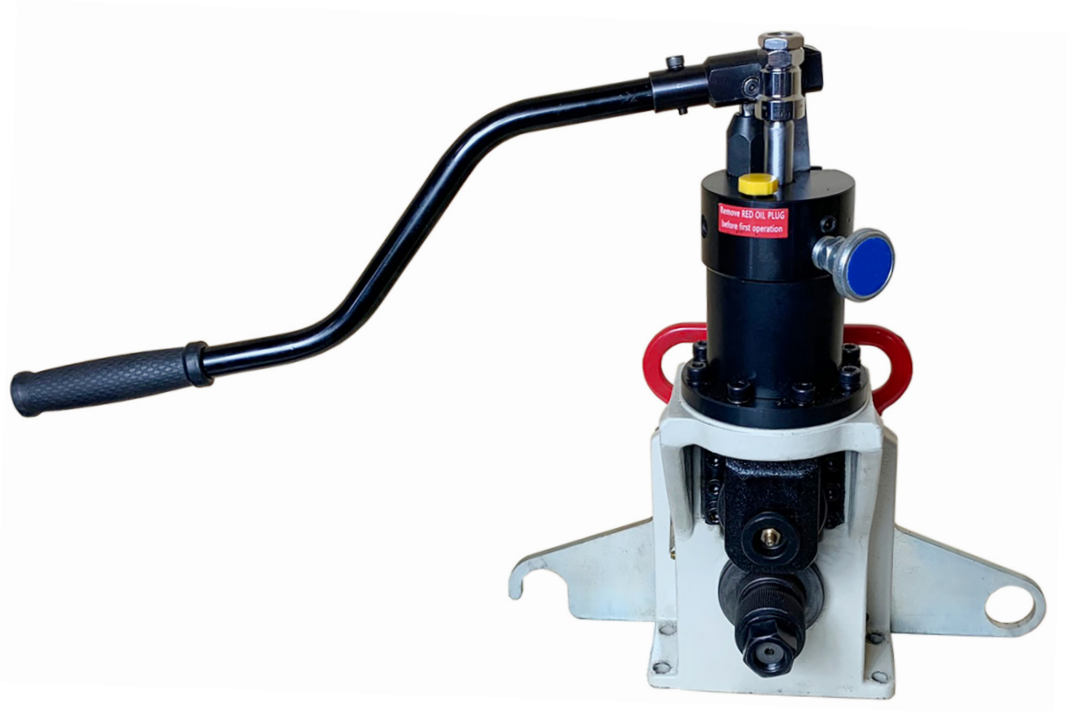

ARGCO RGH-440 LIGHT WEIGHT HYDRAULIC ROLL GROOVER 2" to 8" CAPACITY



WARNING:

Read this Operator's Manual carefully before using this tool. Failure to understand and follow the contents of this manual may result in electrical shock, fire and/or serious personal injury.

GENERAL SAFETY REQUIREMENTS

Work Area Safety

- Keep work zone clean and well-lit. Cluttered or dark areas may bring accidents.
- Do not operate groover in explosive atmospheres, such as in the presence of flammable liquids, gases, or dust. Groover creates sparks which may ignite the dust or fumes.
- Keep children and unnecessary people away while operating a groover.
- Keep floors dry and free of slippery materials such as oil.

Personal Safety

- Stay alert while operating a groover. Do not use a groover while fatigued or under the influence of drugs, alcohol, or medication. Inattention when using groover may result in serious personal injury.
- Use personal protective equipment. Always wear eye glasses.
- Remove any adjusting rulers or wrench before using groover. Tools left attached to a rotating part of the groover may result in personal injury.
- Dress properly. Do not wear loose clothing or jewelry. Keep hair, clothing, and gloves away from moving parts.

Tool Use and Care

- Store idle tools away from children and do not allow persons unfamiliar with the tool or these instructions to use the groover. Roll groover is dangerous in the hands of untrained users.
- Maintain tools. Check for misalignment or binding of moving parts, breakage of parts and any other condition that may affect the tool's operation. If damaged, have the tool repaired before use.
- Use only accessories that are recommended for ARGCO RGH-440 Roll Groover.
- Keep handles dry and clean; free from oil and grease.

Service

- Have the roll groover serviced only by a qualified repair person using identical replacement parts.



Roll Groover Safety

- **Keep hands away from grooving rollers.** Do not wear loose fitting gloves.
- **Keep hands away from ends of pipe.** Burrs and sharp edges may catch and cut.
- **Properly support the pipe** to prevent the tipping of the pipe and equipment.
- **Always wear appropriate personal protective equipment** such as safety glasses, tight fitting leather gloves, steel toed footwear, and a hardhat.
- **Only use roll groover to groove pipe of recommended sizes and types according to these instructions.** Improper use or modification of the roll groover for other applications may increase the risk of injury.
- **When working overhead, all personnel should wear hard hats and be clear of the area below, to prevent serious injuries if groover, pipe or other objects fall.**

Roll Groover Safety When Driven By A Power Drive/ Threading Machine

- **Safety rules of using a power drive/threading machine must comply the safety code from the factory of power drive/threading machine.**
- The ARGCO RGH-440 Hydraulic Roll Groover can be driven by 300 Power Drive or the 300 Compact Threading Machine. Use of unapproved power sources will result in improper set up and could cause tipping or other issues.
- One person must control both the grooving process and the foot switch. Do not operate with more than one person. In case of entanglement, the operator must be in control of the foot switch.
- Only use power drives and threading machines with a rotational speed of **57 rpm or less.** Higher speed machines increase the risk of injury.
- Be sure the roll groover is **properly set up and secured** to the power drive/threading machine. **Be sure the machine, stand, groover and pipe are stable.**



DESCRIPTION, SPECIFICATIONS AND STANDARD

EQUIPMENT DESCRIPTION

ARGCO RGH-440 PORTABLE HYDRAULIC ROLL GROOVER is a roll groover designed with an advanced hydraulic feeding system. It can form roll grooves in steel and aluminum pipe of 2" thru 4" diameter SCH 10/40 and 5" thru 8" SCH 10/20 . It is also designed to groove 2" to 8" schedule 10 and 2" to 4" schedule 40 stainless steel pipe. The grooves are formed by mechanically advancing a grooving roller into the pipe which is supported by a knurl drive shaft. The only adjustment necessary is for the depth of the groove. The unit is specifically designed to be used with a Power Drive (38 and 57 RPM Models). With a Drive Bar Adapter, the unit can also work with the carriage left in place. The ARGCO RGH-440 Hydraulic Roll Groover is a heavy duty machine intended for heavy volume work in the shop or on job sites.



Specifications

Capacity	2" – 4" Schedule 10/40 and 5" – 8" Schedule 10/2 Steel pipe with roller change
	(See Table I for Wall Thickness)
Max. Pipe Wall thickness (T)	(.236"/6 mm)
Groove Diameter Lock device	Stop knob
Operation Methods.....	Manual, or
by 300 Power Drive (38 and 57 RPM Model Only), or
by 300 Compact Threading Machine (with adapter)
Weight.....	approx.66 lbs./ 30kgs
Groove specification.....	AWWA C606-87

Standard Equipment



Drive shaft
2" thru 8"



Groove roller
2" thru 8"



11018
Drive Bar Adapter

GROOVING PROCESS

Pre-check before grooving powered by 300 Threading Machine

- A. Install the drive bar adapter onto the roll groover drive shaft (See Figure A). Firmly tighten set screws on the roll groover drive shaft.
- B. Place the RGH-440 Support Bench (Item code #13006) on the arms of the adapter bracket with the drive bar adapter in the chuck of the machine. (See Figure B) Close and tighten the threading machine chuck onto the drive bar adapter. Make sure that the drive bar is centered in the chuck. Use repeated and forceful counterclockwise spins of the speed chuck hammer wheel to securely grip the drive bar.

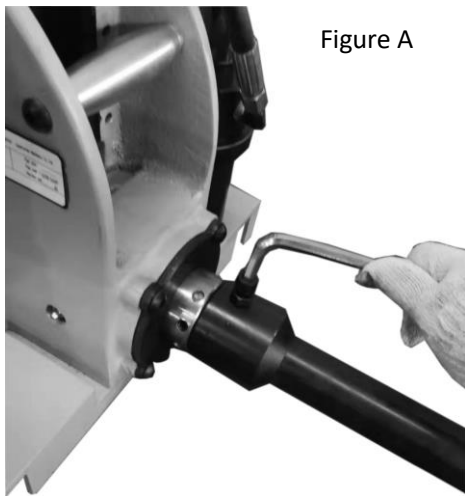

Figure A



Figure B

- C. Check the power drive/threading machine to make sure that it is operating correctly:
 - Move the switch to the FOR (Forward) position. Press and release the foot switch. Confirm that the driveshaft rotates in a counter-clockwise direction as you face the front chuck. If the unit does not rotate in the correct direction or the foot switch does not control the machine operation, do not use the machine until it has been repaired.
 - Depress and hold the foot switch. Check the rotational speed of the unit. Inspect the moving parts for misalignment, binding, odd noises or any other unusual conditions. Release foot switch. If the rotational speed exceeds 57 rpm, do not use the unit for roll grooving. Higher speeds may increase the risk of injury. If unusual conditions are found, do not use the equipment until it has been repaired.
 - Move the switch to the REV (reverse) position. Press and release the foot switch. Confirm that the driveshaft rotates in a clockwise direction as you face the front of the chuck. If the unit does not rotate in the correct direction, do not use the machine until it has been repaired.
 - Move the switch to the OFF position. Unplug the machine with DRY hands.

Pipe Preparation

These are generalized instruction only. Always follow grooved coupling manufacturer's specific recommendations for pipe end preparation. Failure to follow the grooved coupling manufacturer's recommendations may lead to an improper connection and cause leaks.

1. Cut pipe to proper length. Make sure pipe end is cut square and free of burrs. Cut off method and large burrs can affect the quality of the groove made and the tracking of the groove. Do not attempt to groove pipe that has been cut with a torch.
2. All internal/external weld bead, flash, or seams must be ground flush at least 2" back from the end of the pipe. Do not cut flats into gasket seat area, this could cause leaks.
3. Remove all scale, dirt, rust and other contaminants **at least 2"/50mm back** from the end of the pipe. Contaminants can clog the drive knurls and prevent proper driving and tracking of the pipe while grooving.
4. When using power drive to roll groove pipes, make sure you have the appropriate support available for pipes to be grooved. Pipes equal to or **over 36"/1.0meter** should be supported with **at least two pipe stands**. Failure to properly support the pipe may allow the pipe or the pipe and machine to tip and fall.

Preparation of roll grooving with a power drive

1. Place the required pipe stands in front of the roll groover. For lengths supported by a single stand, the stand should be placed slightly more than half the length of the pipe from the roll groover cover plate. For lengths of pipe requiring more than one stand, the stands should be placed 1/4 of the pipe length from the ends of the pipe. It may be appropriate to use more stands in some situations. Stand height should be adjusted so that the pipe can fit over the drive roller.
2. Make sure the groove roll and drive shaft fit the size of the pipe intending to be roll grooved.
3. Raise upper groove roller housing by turning the pump knob counter-clockwise, in "OFF" direction (always towards operator), to allow the pipe to be placed over the drive shaft.
4. Place the pipe end over the driveshaft and set the pipe down onto the pipe stands. Make sure the pipe is stable.
5. Adjust pipe and pipe stands so that the end of the pipe is flush with the groover's cover plate, and the inside of the pipe contacts the top of the driveshaft. The centerline of the pipe and the centerline of the drive shaft should be parallel to one another. One way to do this is to level both the pipe and the power drive/threading machine.
6. Plug the machine into the properly grounded outlet with DRY hands.

Start A Test Grooving

A test grooving should be always performed when setting up or changing pipe sizes.

1. Turn the pump knob clockwise, in "ON" direction, till full close. Press down the pump lever to push down the groove roller in contact with the pipe top surface.
2. Turn down the stop knob clockwise until it contacts the oil cylinder top surface. The pipe and roll groover should be secure to each other at this stage.



3. Depending on required groove depth (refer to Chart B “Groove Parameters”), turn the stop knob counter-clockwise. Each full circle is approximately 1/16” (2mm).
4. Start the power drive/thread machine by stepping on the foot switch while pressing down the pump lever. Allow one full pipe rotation between quarter strokes of the pump lever.
5. When the stop knob contacts the cylinder top surface, allow two more full pipe rotation.
6. Stop the power drive/threading machine by releasing foot switch. Loosen the pump knob counter-clockwise and perform groove inspection. Use a groove tape to check groove diameter.
7. If the groove is too large, the groover can be adjusted and the groove will be made smaller by turning stop knob counter-clockwise slightly. Repeat steps 4 -6. If the groove is too small, turn the stop knob clockwise slightly. Another groove will need to be made. Proper groove diameter is important to insure connection performance. Out of spec grooves can cause joint failure.

Roll grooving with RGH-440

1. After the test groove is made and the groove meets requirement, make sure the stop knob is touching the oil cylinder surface. The roll groover is ready to operate on pipes of the same size.
2. Repeat steps 3-5 in “Preparation of roll grooving with a power drive” section and steps 3-5 in “Roll grooving with RGH-440” for more grooving.
3. **Implement at least one groove diameter inspection after every 5 grooves that are formed.**

Prevent spiral grooving

If the groove on pipe looks spiral or the pipe walks off from the groover, follow the instructions below to solve the problem:

- Slightly offset the pipe and pipe stands approximately 1/2 degree (about 1" over at 10 feet/ 25mm over at 3.0meters from the roll groover) away from the operator. Proper alignment of the pipe and roll groover helps to insure proper tracking of the pipe while grooving.
- The Operator may need to apply slight force (opposite to the pipe rotation) on the pipe while roll grooving. The operator should wear leather gloves and cup his hand on the center of the pipe. **Always keep hand away from the grooving roller and the end of the pipe to prevent injuries.**

Changing Roller Sets

Always open the relief valve on hydraulic pump counter-clockwise and raise the groove roller to the top position. Refer to Figure 3.

1. Remove Drive Shaft

Loosen the shaft bolt in the center of drive shaft on the front side (roll side) with a 5/16"(10mm) hex wrench. Grasp the knurl drive shaft and remove. (Figure C)

2. Remove Groove Roller

Loosen the set screw on the side block with a 3/16" (5mm) hex wrench. Grasp the groove roller steady and draw out the groove shaft from the side block. (Figure D)

3. Reverse step 1 & 2, install suitable groove roller and drive roller as demanded.

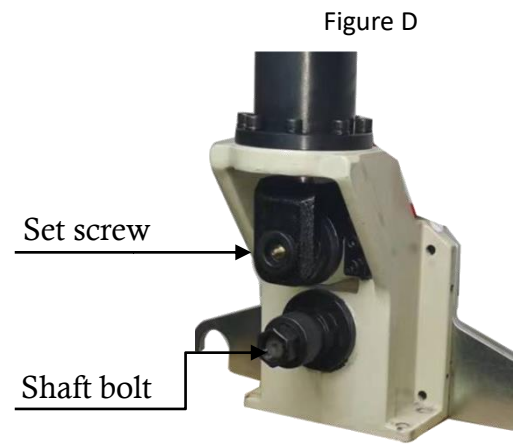
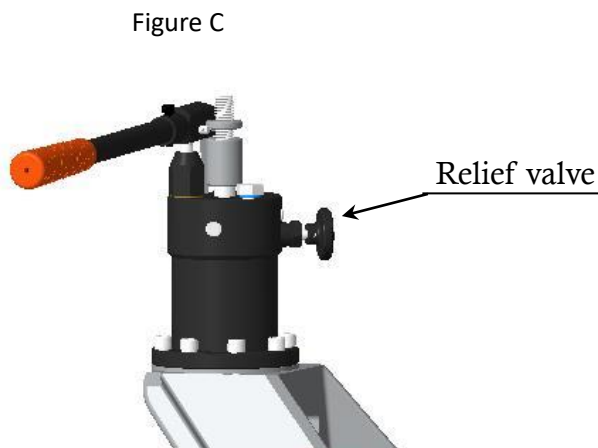

MAINTENANCE INSTRUCTIONS

Lubrication

RGH-440 should be lubricated with a good general purpose lubricant periodically as specified below.

- 2 Grease nozzles are integrated on RGH-440 groover. Drive Shaft grease nozzle is located on the side of the groover housing. Groove roller nozzle is located at the front-center of the roller pin. Always add grease until a small amount is pushed out. (Refer to Figure E)
- **At least every 4 hours of operation**, lubricate the roller shaft.
- **Every month**, add grease to the drive shaft lubrication nozzle.
- The gear box of the RGH-440 Hydraulic Roll Groover is greased for the life of the groover and does not require the addition of any grease unless the gear box is opened. See Inspection Section for other information on maintenance.

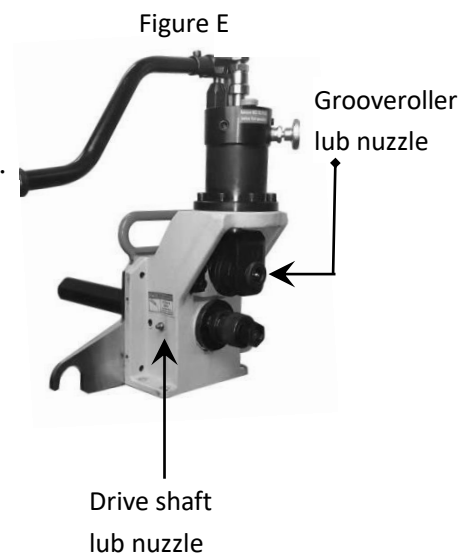



Cleaning

- Clean the drive shaft knurls with a wire brush on a daily basis or more often if needed.
- Clean the unit surface with dry soft cotton cloth.

Machine Storage

- Store the tool in a locked area that is out of reach of children and people unfamiliar with roll groover equipment. This tool can cause serious injury in the hands of untrained users.
- Store the tool in a locked area away from moisture and corrosive materials. Applying a thin coat of anti-rust liquid on moving parts and shafts is strongly recommended.

Accessories

The following ARGCO products have been designed to function with the RGH-440 Hydraulic Roll Groover. Other accessories suitable for use with other tools may be hazardous when used on the RGH-440 Hydraulic Roll Groover. To reduce the risk of serious injury, only use accessories specifically designed and recommended for use with the RGH-440 Hydraulic Roll Groover, such as those listed in the Chart A.

Chart A – Accessories of RGH-440 Hydraulic Roll Groover

Accss.	Dscpt	Part No.	Accss.	Dscpt	Part No.
Groove	2"-6"	#12018	Drive Bar Adapter		#11018
Rollers	8"	#12032	Pump lever		#19015
Drive	2" ~ 6"	#11074	Tools kit		#97004
Shafts	8"	#11075	User manual		#96004

Service and Repair

The "Maintenance Instructions" will take care of most of the service needs of this machine. Any problems not addressed by this section should only be handled by an authorized ARGCO service technician. When servicing this machine, only identical replacement parts should be used. Use of other parts may create a risk of serious injury. If you have any questions regarding the service or repair of this machine, please contact us at ARGCO.com.

Chart B - Roll grooving parameters

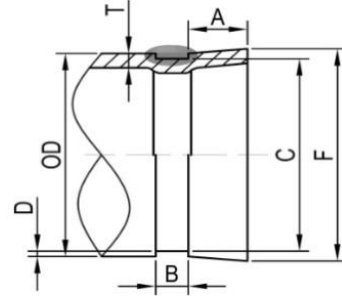
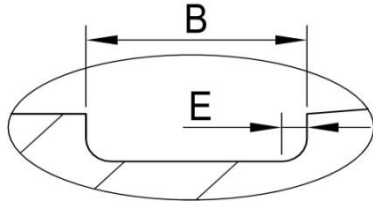

Nom. Pipe Size	Pipe O.D.			Gasket Seat A	Groove Width B	Groove Diameter		Groove Depth D(ref.)	Allow. Flare Dia. F(max)
	Basic	Tolerance				Basic	Tol.		
in. mm	in. mm	+in. + mm	-in. -mm	±0.03in. ±0.76mm	±0.03in. ±0.76mm	in. mm	in. mm	in. mm	in. mm
2" 50	2.375 60.3	0.024 0.61	0.024 0.61	0.625 15.88	0.344 8.74	2.250 57.15	-0.015 -0.38	0.063 1.60	2.48 63.0
2½" 65	2.875 73.0	0.029 0.74	0.029 0.74	0.625 15.88	0.344 8.74	2.720 69.09	-0.018 -0.46	0.078 1.98	2.98 75.7
3OD 65	3.000 76.1	0.030 0.76	0.030 0.76	0.625 15.88	0.344 8.74	2.845 72.26	-0.018 -0.46	0.078 1.98	3.10 78.7
3" 80	3.500 88.9	0.035 0.89	0.031 0.79	0.625 15.88	0.344 8.74	3.344 84.94	-0.018 -0.46	0.078 1.98	3.60 91.4
3½" 90	4.000 101.6	0.040 1.02	0.031 0.79	0.625 15.88	0.344 8.74	3.834 97.38	-0.020 -0.51	0.083 2.11	4.10 104.1
4" 100	4.500 114.3	0.045 1.14	0.031 0.79	0.625 15.88	0.344 8.74	4.334 110.08	-0.020 -0.51	0.083 2.11	4.60 116.8
4½OD 120	5.000 127.0	0.050 1.27	0.031 0.79	0.625 15.88	0.344 8.74	4.834 122.78	-0.020 -0.51	0.083 2.11	5.10 129.5
5½OD 125	5.500 139.7	0.056 1.42	0.031 0.79	0.625 15.88	0.344 8.74	5.334 135.48	-0.020 -0.51	0.083 2.11	5.60 142.2
5" 125	5.563 141.3	0.056 1.42	0.031 0.79	0.625 15.88	0.344 8.74	5.395 137.03	-0.022 -0.56	0.084 2.13	5.66 143.8
6½OD 150	6.500 165.1	0.063 1.60	0.031 0.79	0.625 15.88	0.344 8.74	6.330 160.78	-0.022 -0.56	0.085 2.16	6.60 167.6
6" 150	6.625 168.3	0.063 1.60	0.031 0.79	0.625 15.88	0.344 8.74	6.455 163.96	-0.022 -0.56	0.085 2.16	6.73 170.9
8OD 200	8.000 203.2	0.063 1.60	0.031 0.79	0.750 19.05	0.469 11.91	7.816 198.53	-0.025 -0.64	0.092 2.34	8.17 207.5
8" 200	8.625 219.1	0.063 1.60	0.031 0.79	0.750 19.05	0.469 11.91	8.441 214.40	-0.025 -0.64	0.092 2.34	8.80 223.5